

NFAS

NFAs

- An *NFA* is a
 - *N*ondeterministic
 - *F*inite
 - *A*utomaton
- Structurally similar to a DFA, but represents a fundamental shift in how we'll think about computation.

(Non)determinism

- A model of computation is ***deterministic*** if at every point in the computation, there is exactly one choice that can make.
- The machine accepts if that series of choices leads to an accepting state.
- A model of computation is ***nondeterministic*** if the computing machine may have multiple decisions that it can make at one point.
- The machine accepts if ***any*** series of choices leads to an accepting state.

A Simple NFA

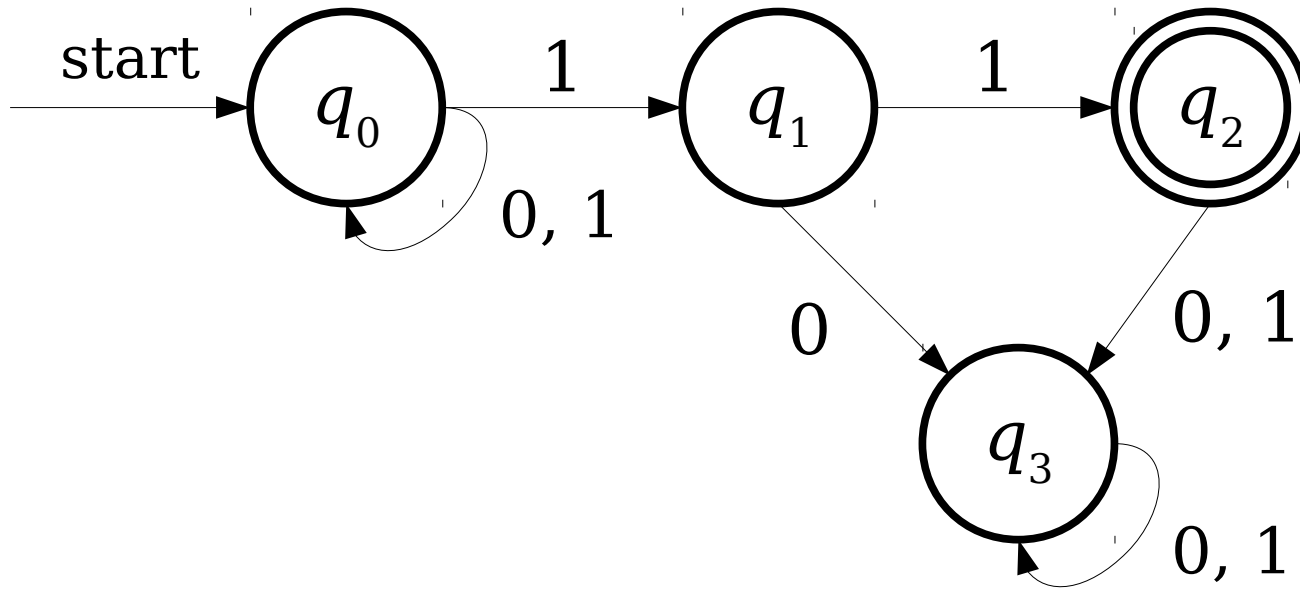

A Simple NFA

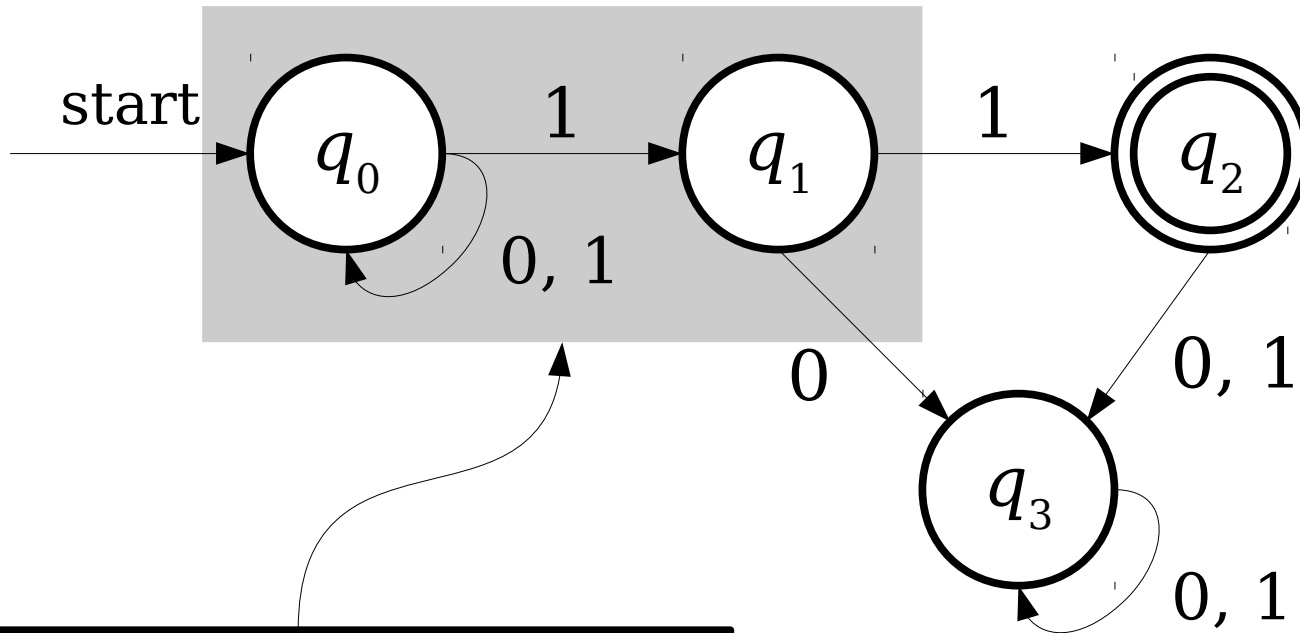

q_0 has two transitions defined on 1!

A Simple NFA

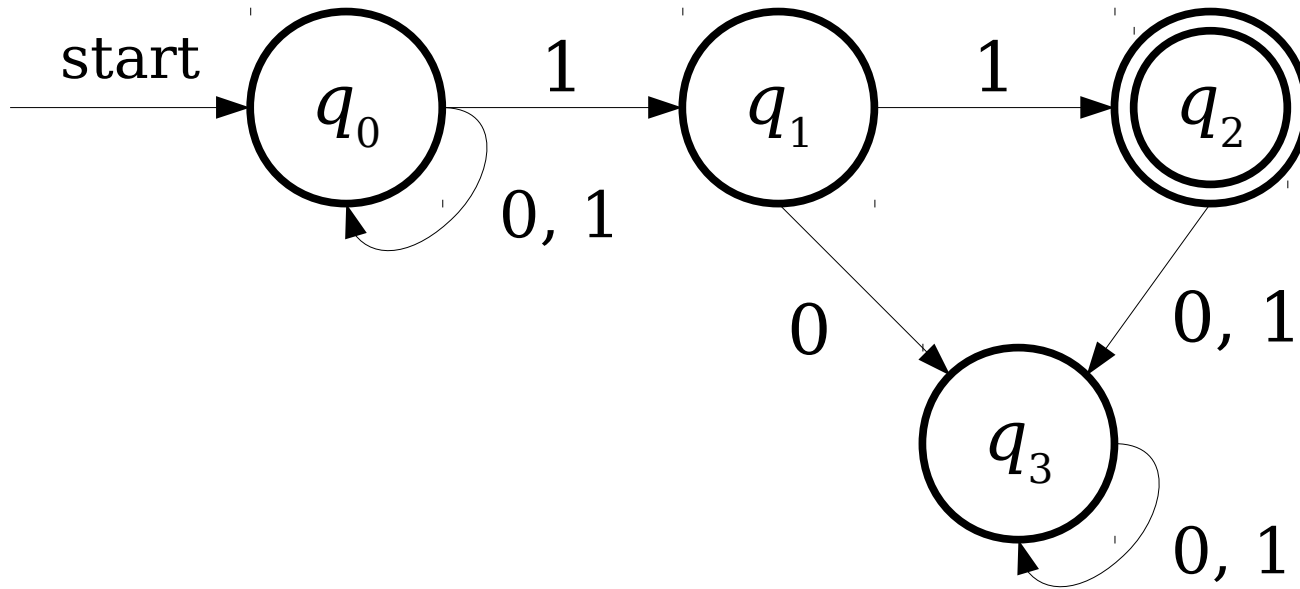

0 1 0 1 1

A Simple NFA

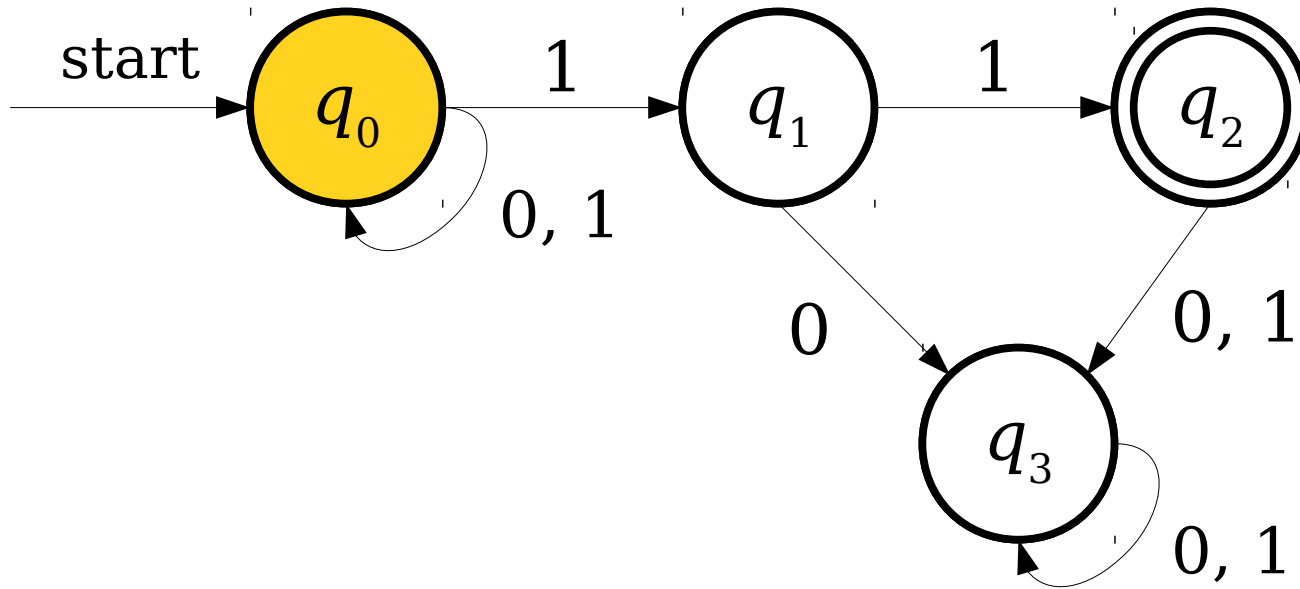

0 1 0 1 1

A Simple NFA

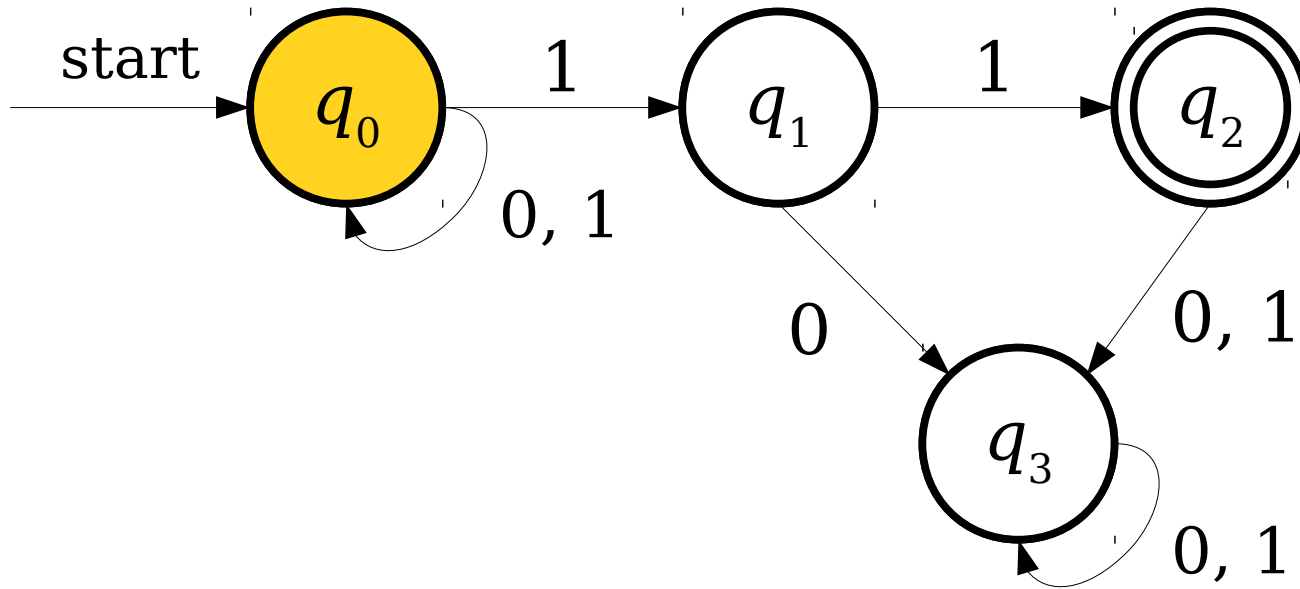

0 1 0 1 1

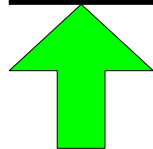

A Simple NFA

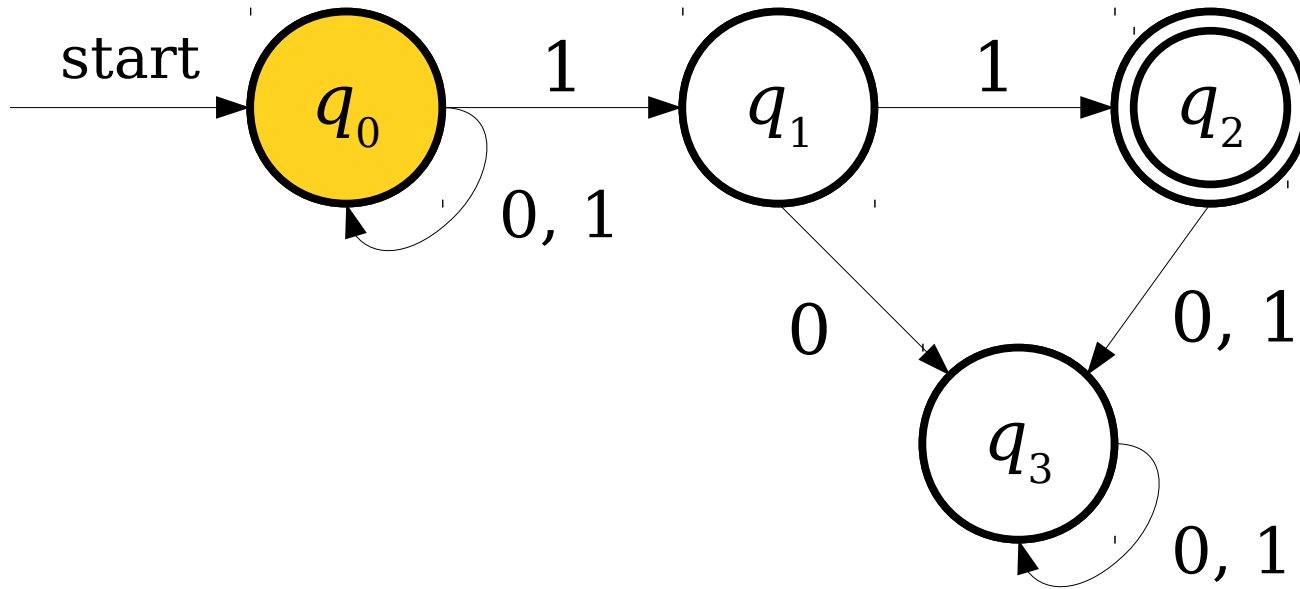

0 1 0 1 1

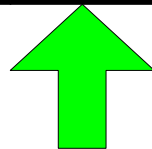

A Simple NFA

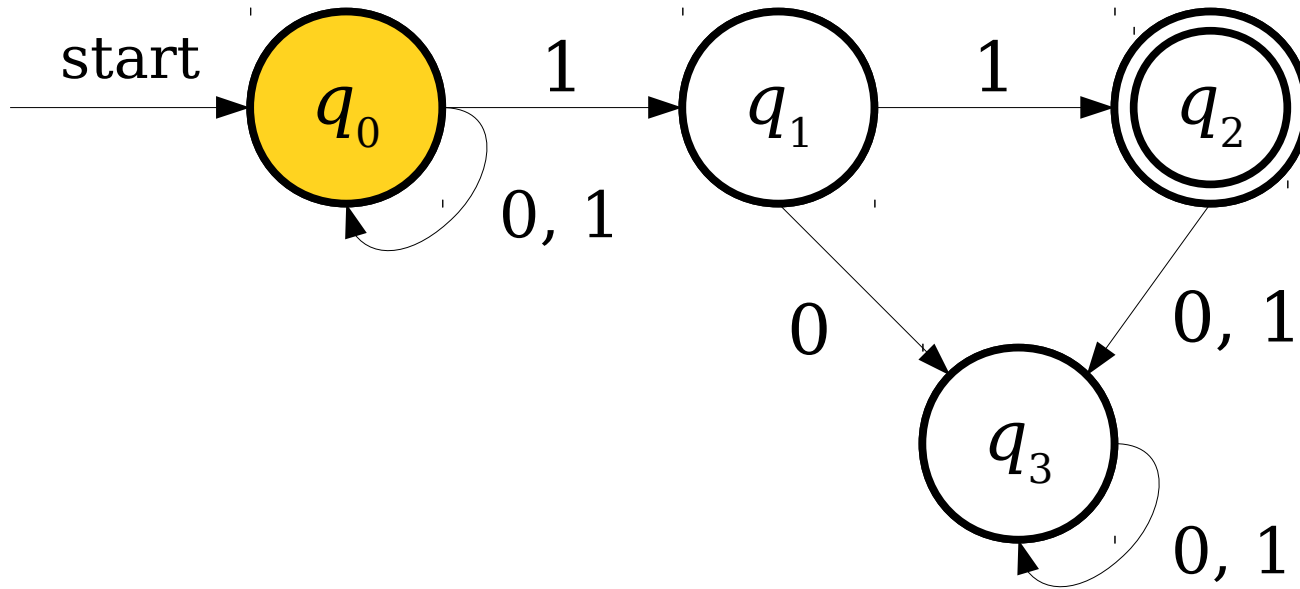

0 1 0 1 1

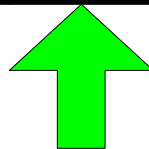

A Simple NFA

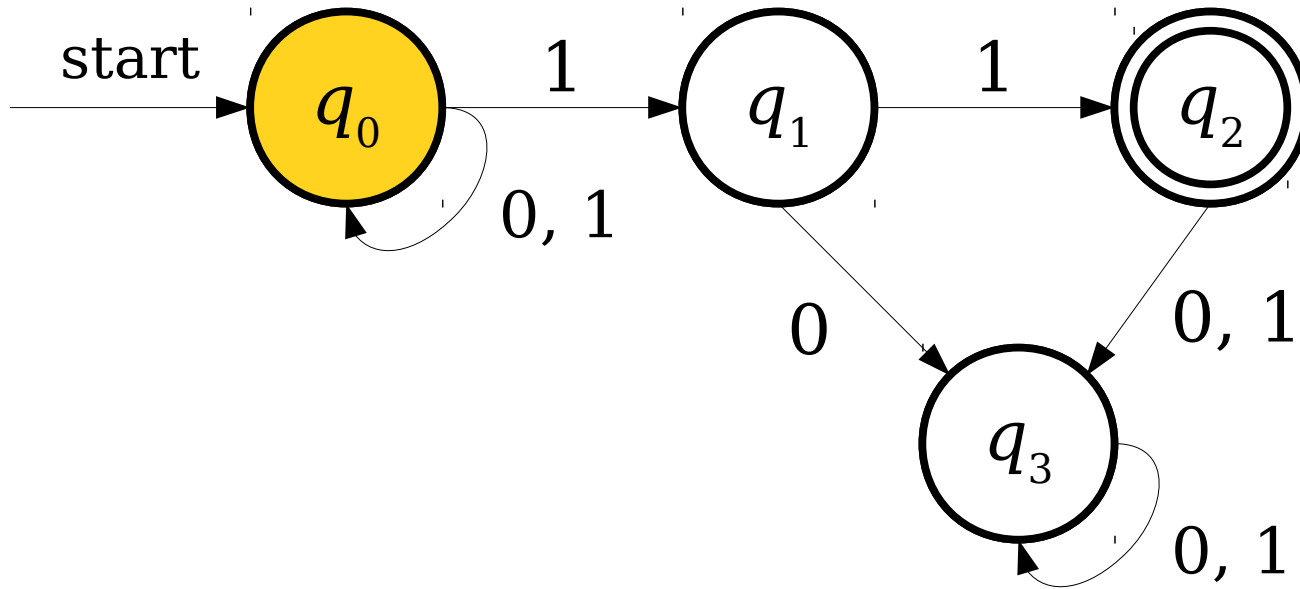

0 1 0 1 1

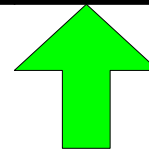

A Simple NFA

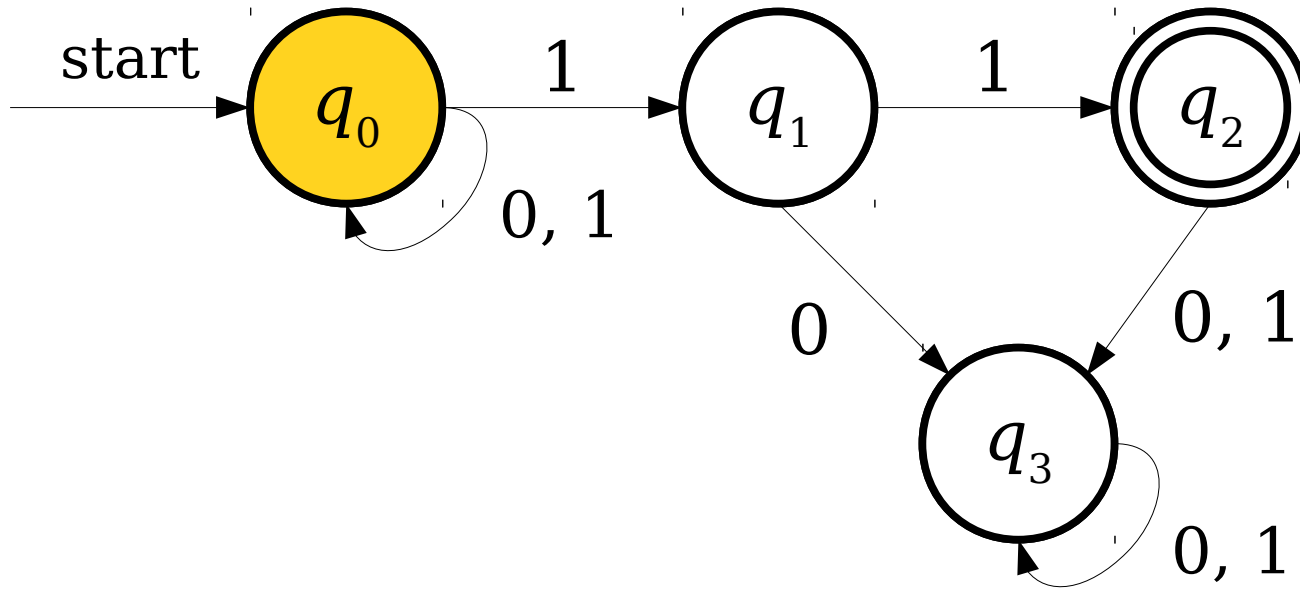

0 1 0 1 1

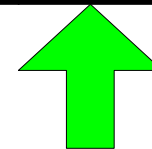

A Simple NFA

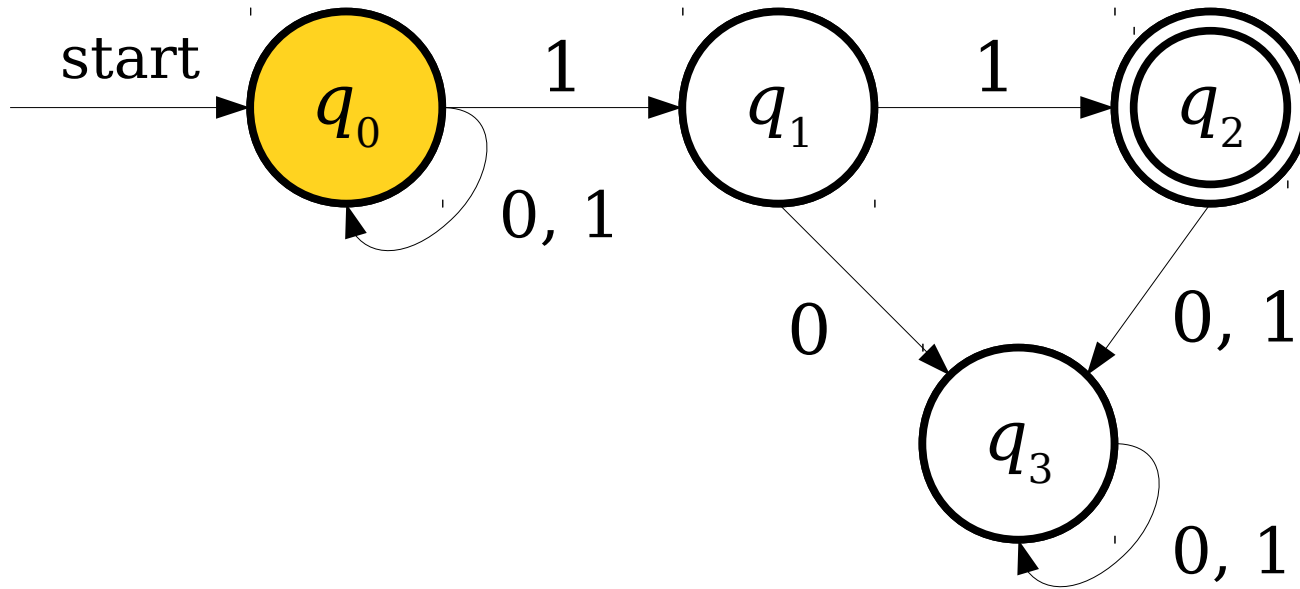

0 1 0 1 1

A Simple NFA

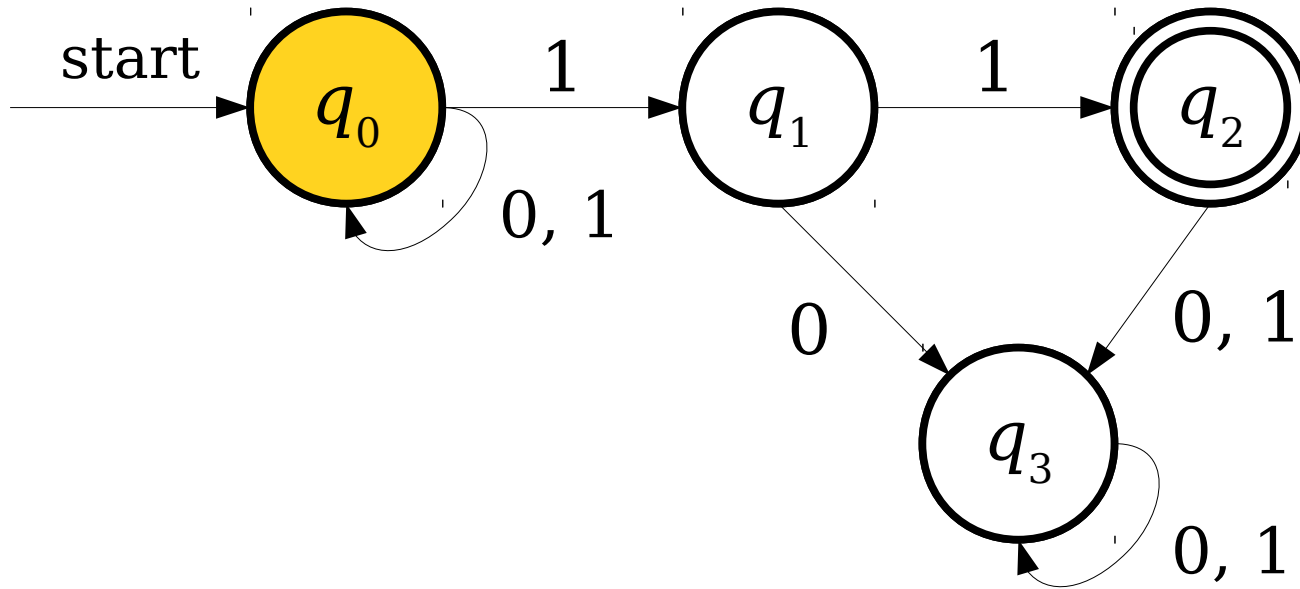

0 1 0 1 1

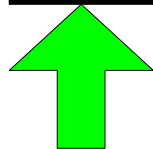

A Simple NFA

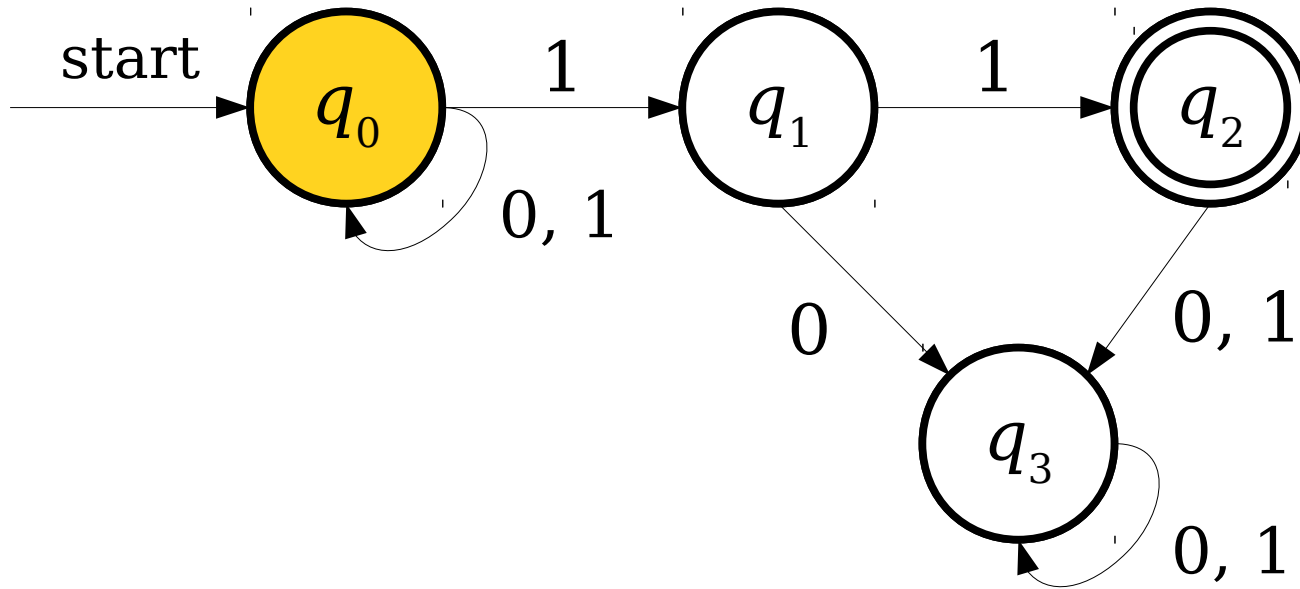

0 1 0 1 1

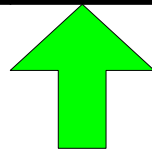

A Simple NFA

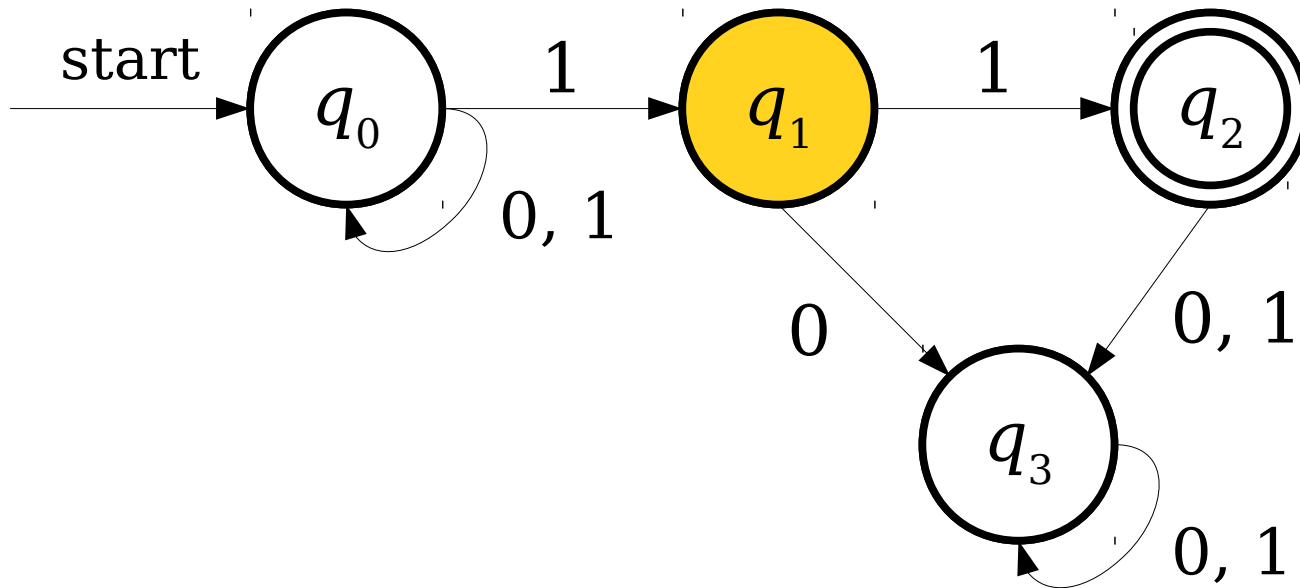

0 1 0 1 1

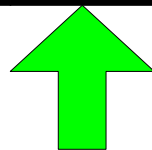

A Simple NFA

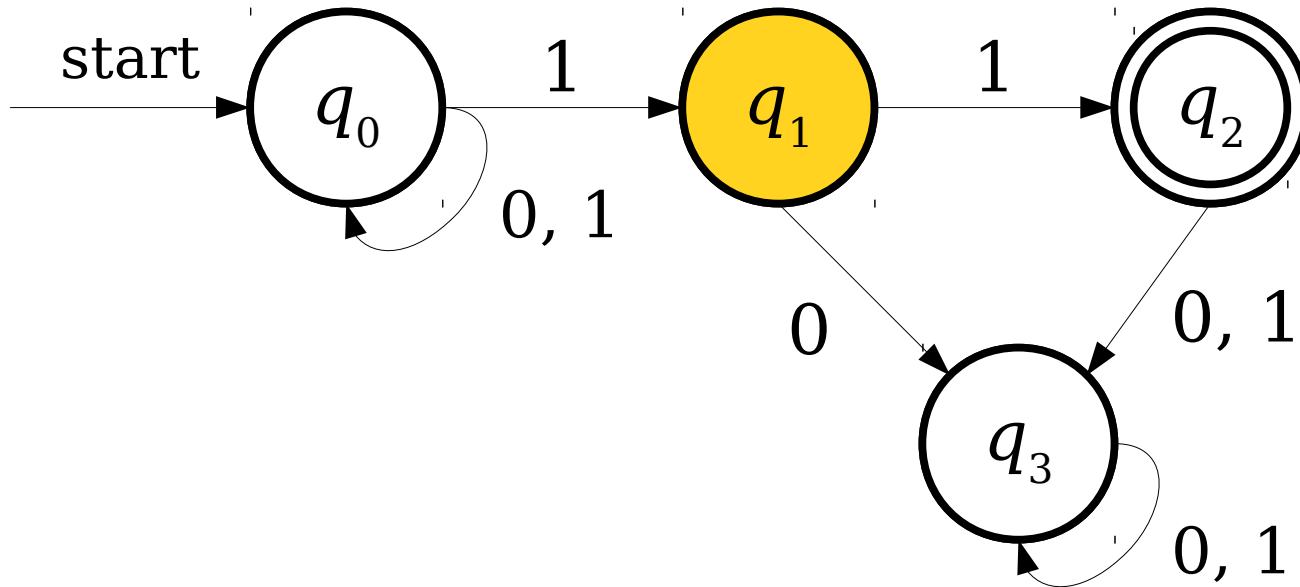

0 1 0 1 1

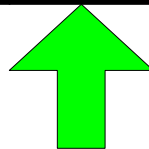

A Simple NFA

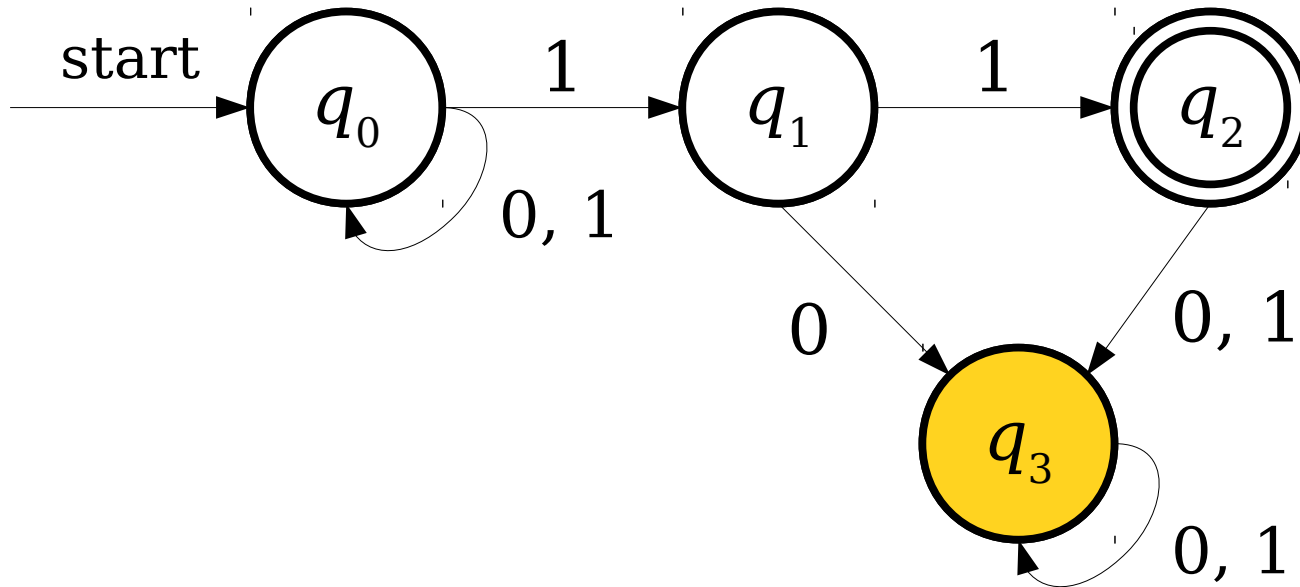

0 1 0 1 1

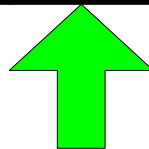

A Simple NFA

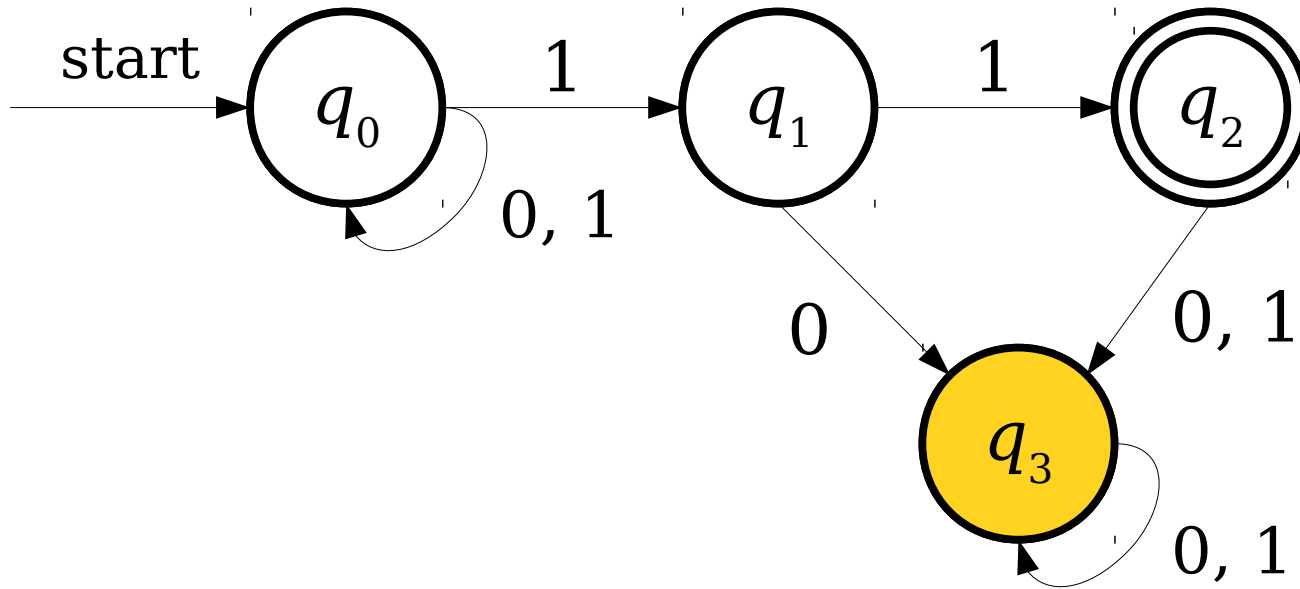

0 1 0 1 1



A Simple NFA

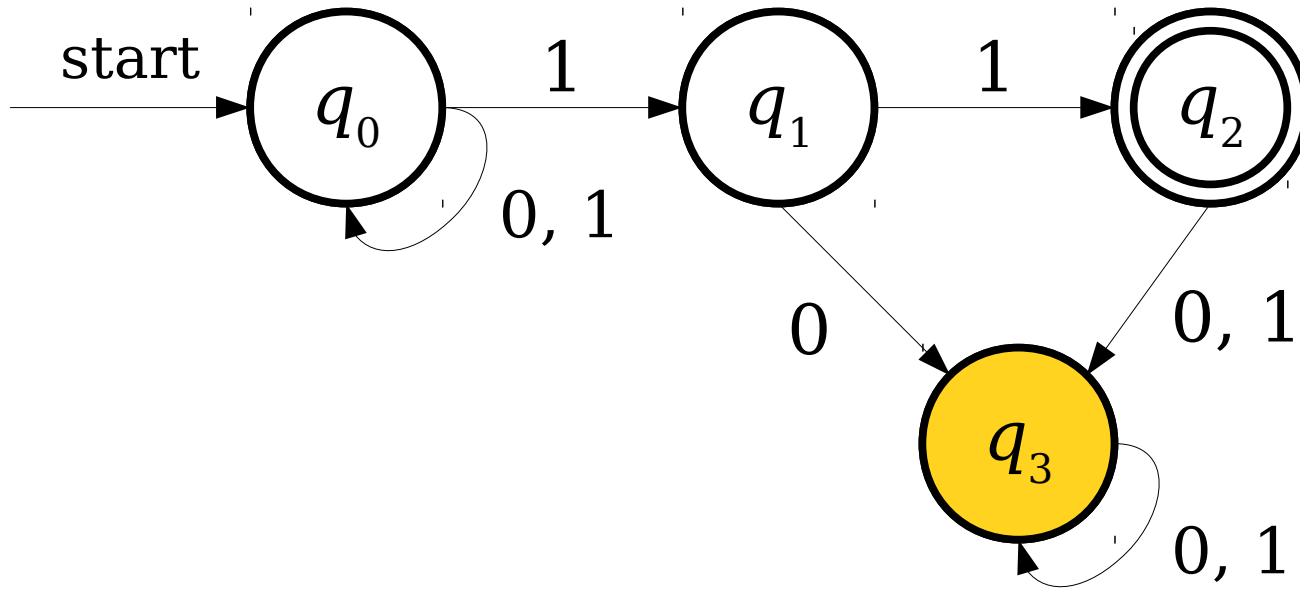

0 1 0 1 1

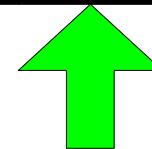

A Simple NFA

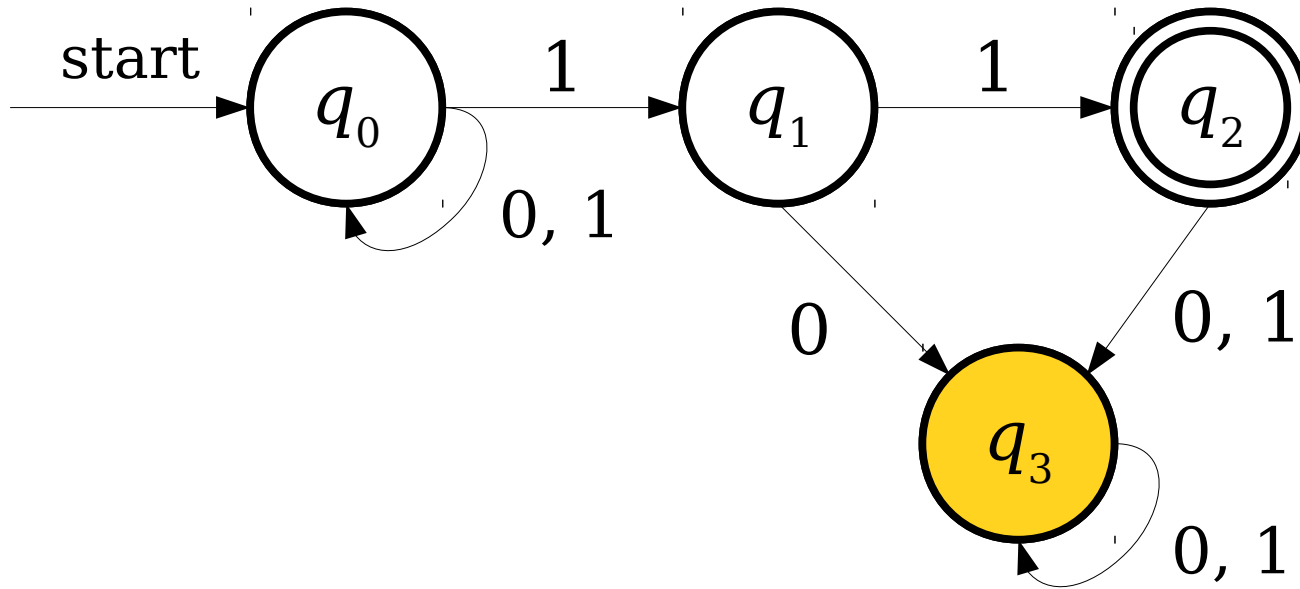

0 1 0 1 1

A Simple NFA

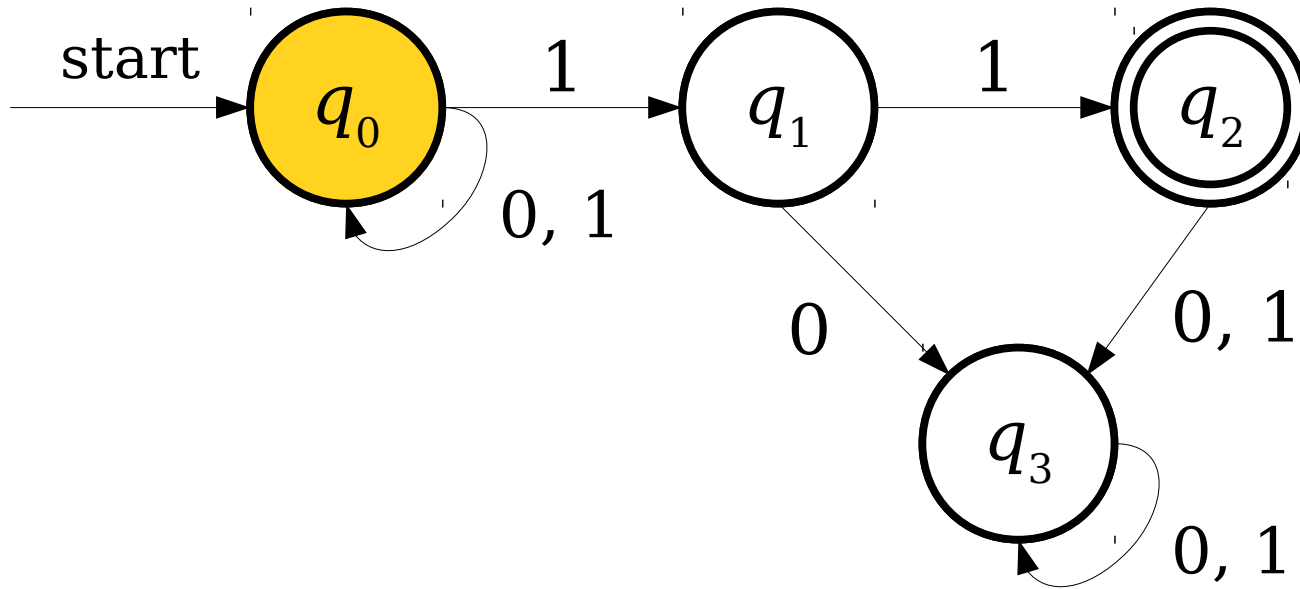

0 1 0 1 1

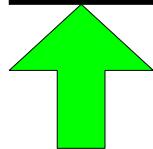

A Simple NFA

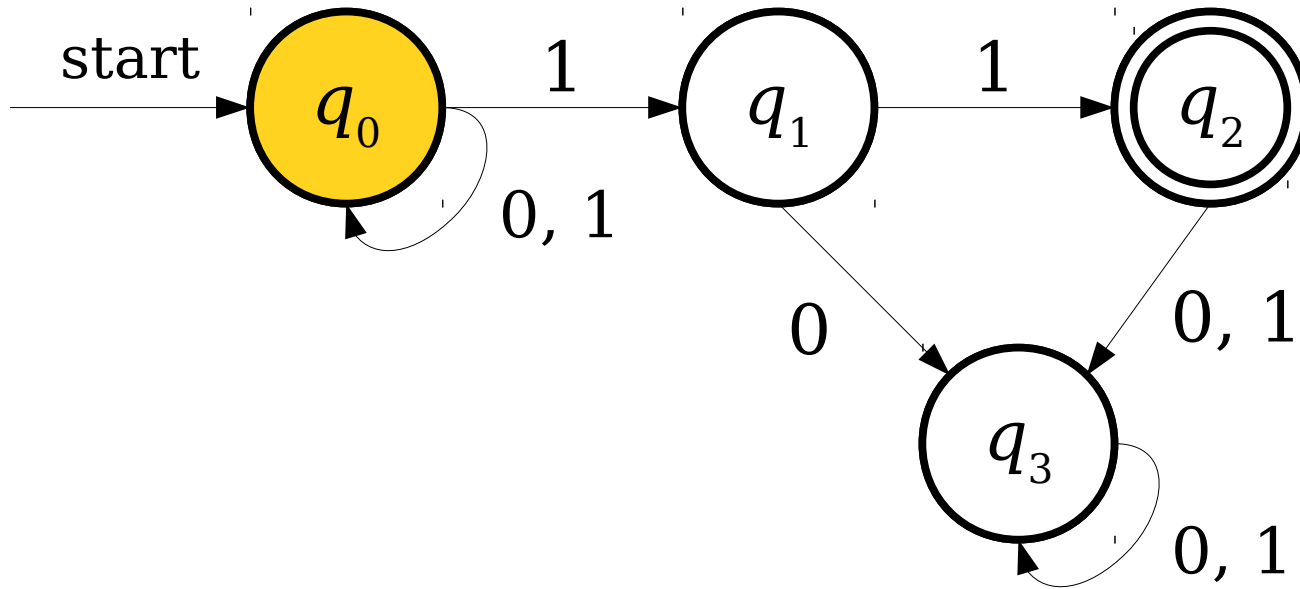

0 1 0 1 1

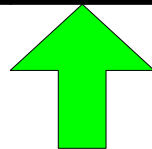

A Simple NFA

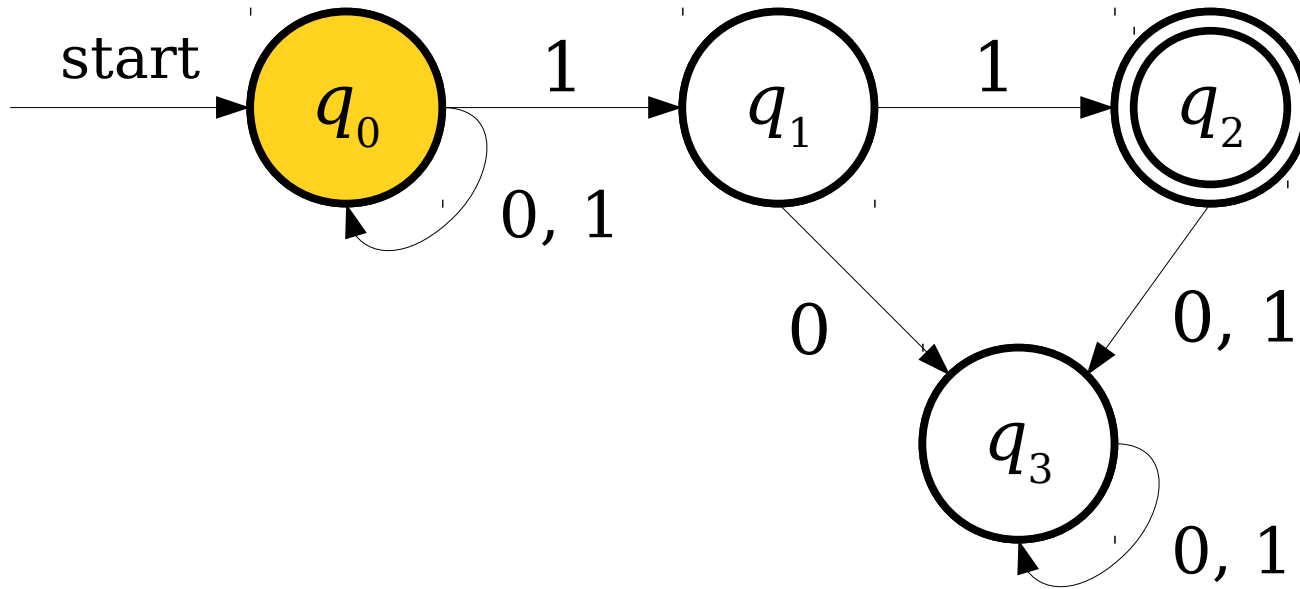

0 1 0 1 1

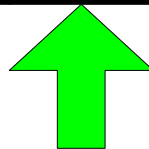

A Simple NFA

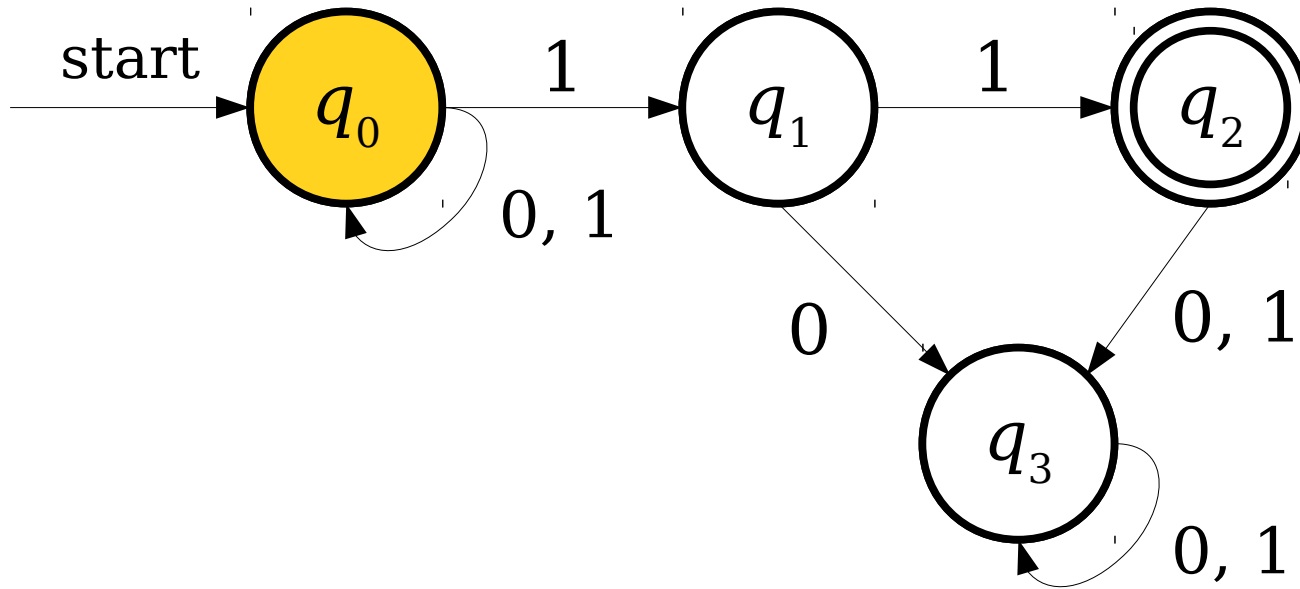

0 1 0 1 1

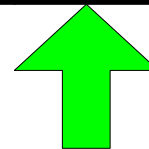

A Simple NFA

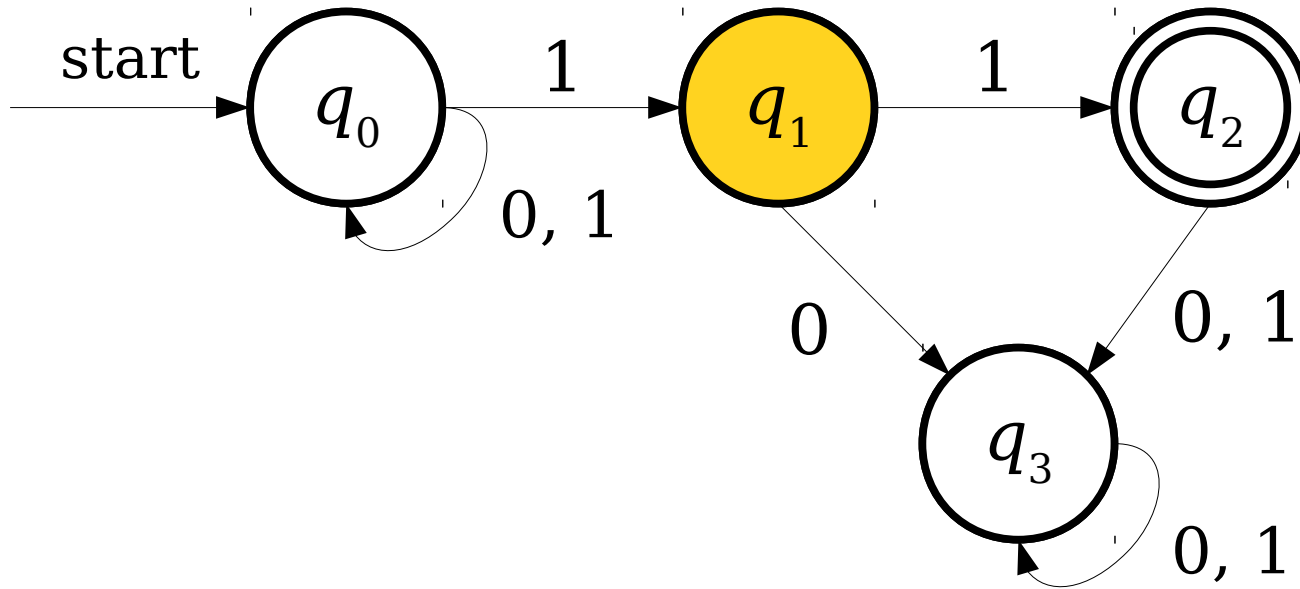

0 1 0 1 1



A Simple NFA

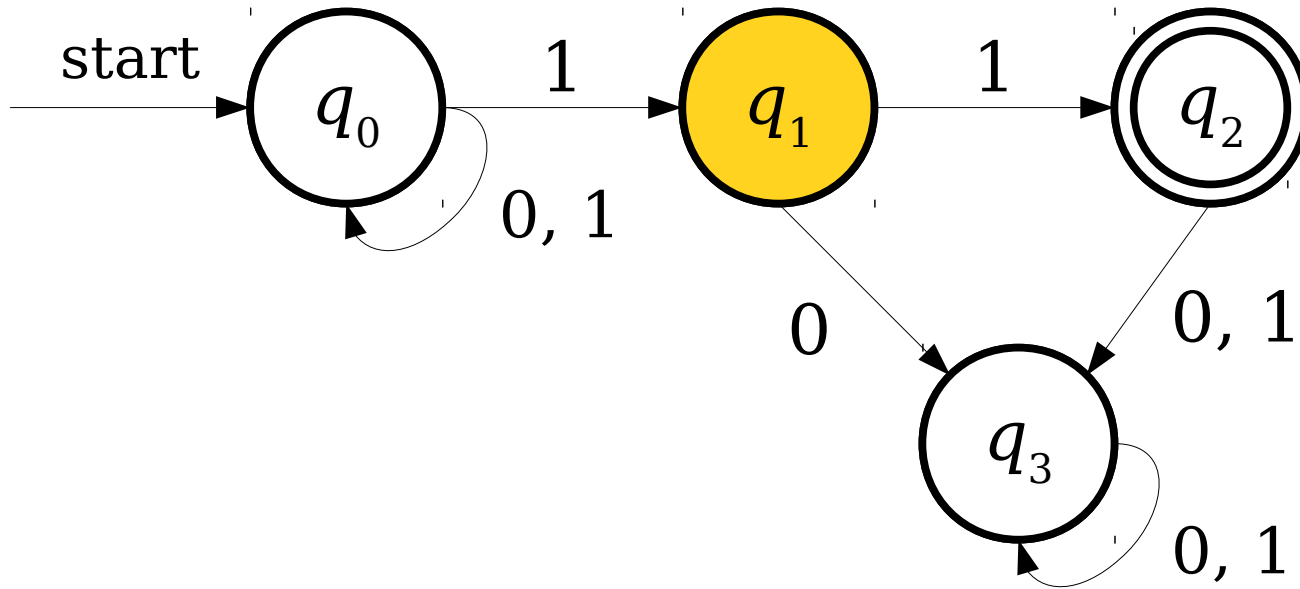

0 1 0 1 1

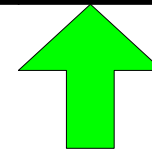

A Simple NFA

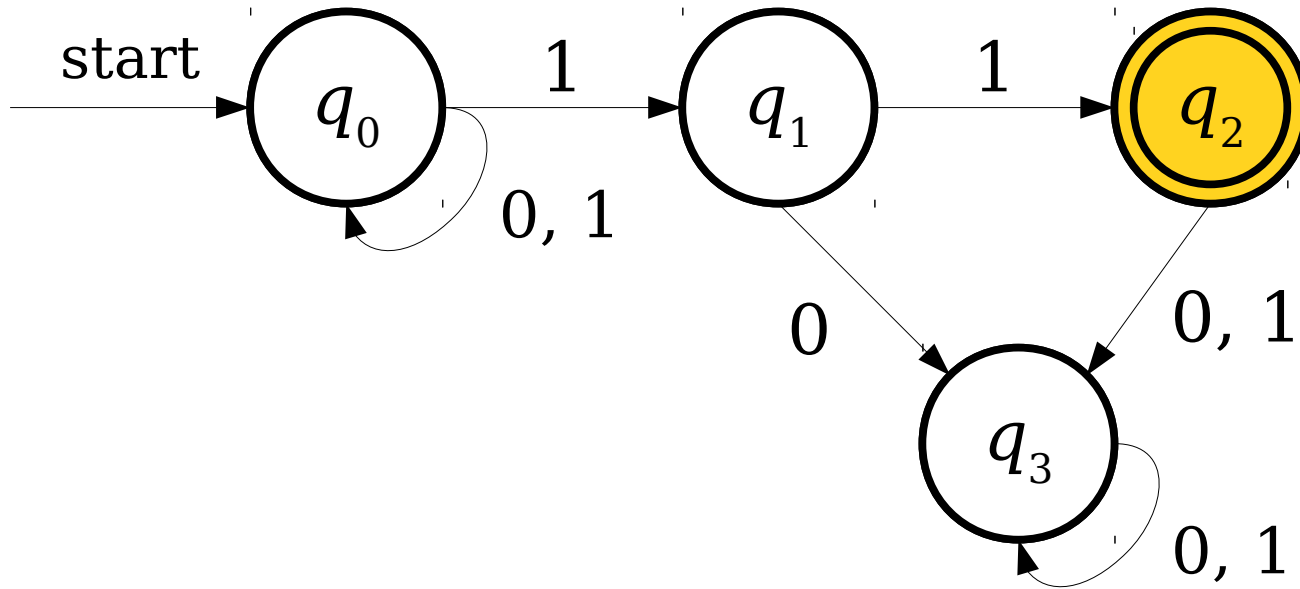

0 1 0 1 1

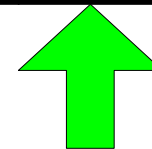

A Simple NFA

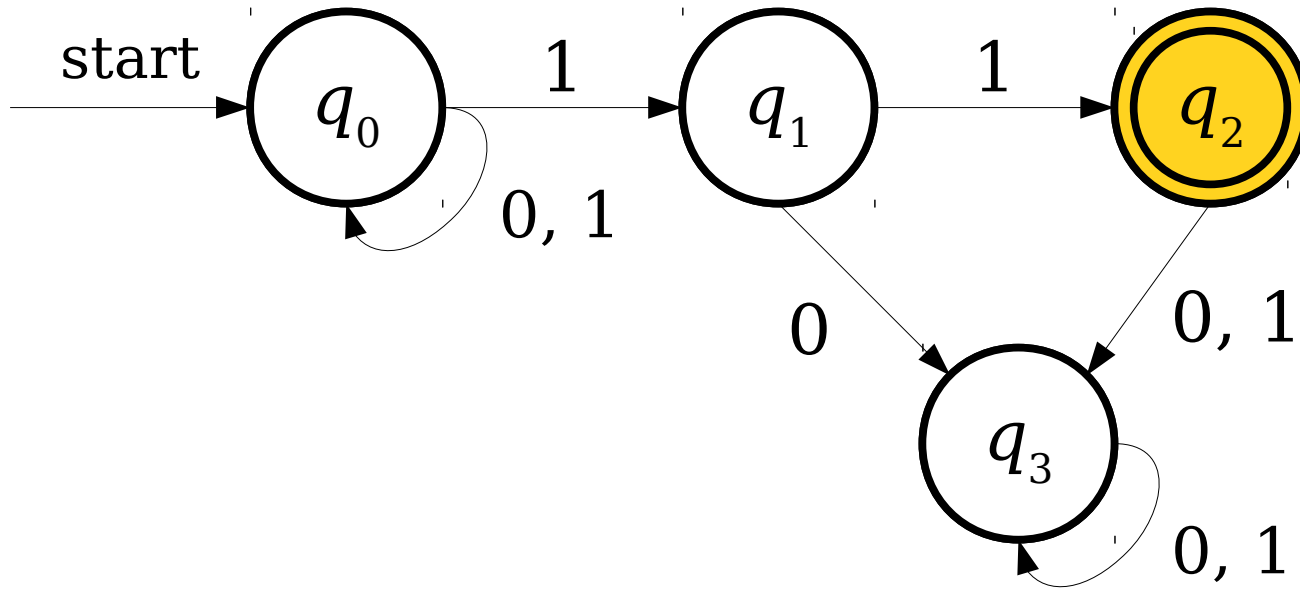

0 1 0 1 1

A Simple NFA

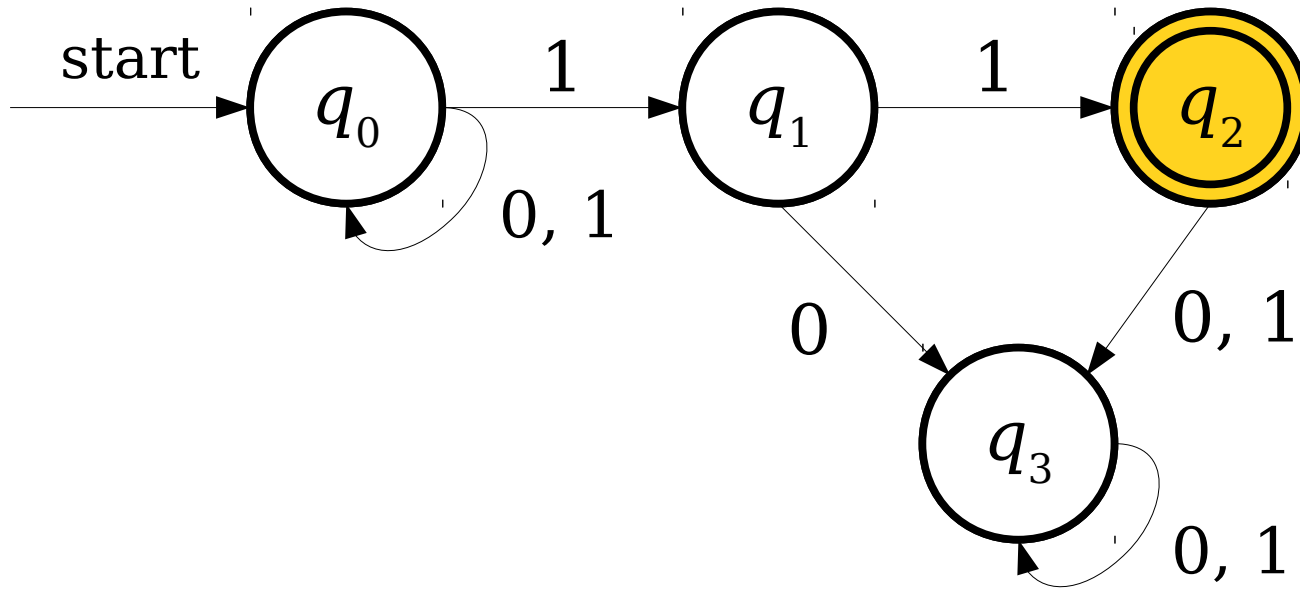

0 1 0 1 1

A Simple NFA

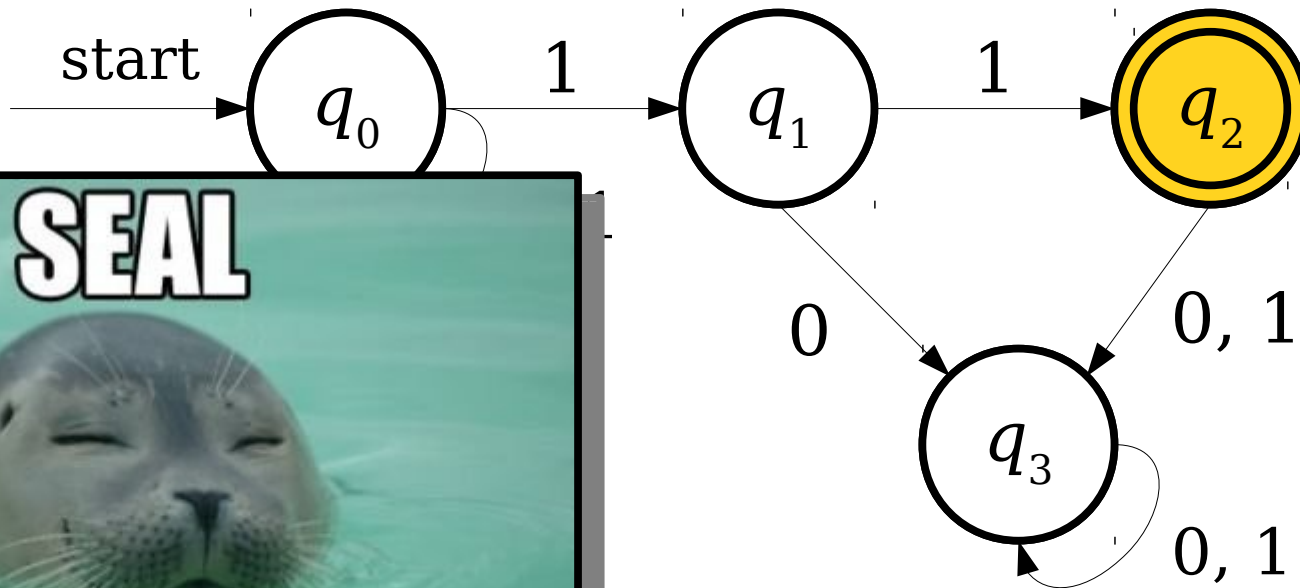

0 1 0 1 1

A More Complex NFA

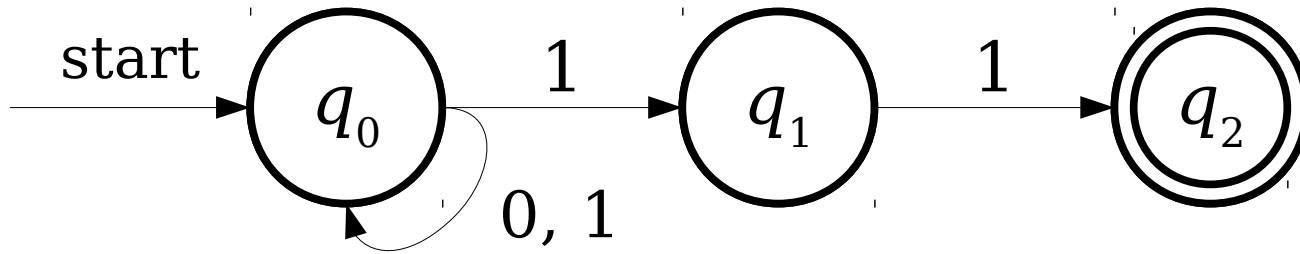

A More Complex NFA

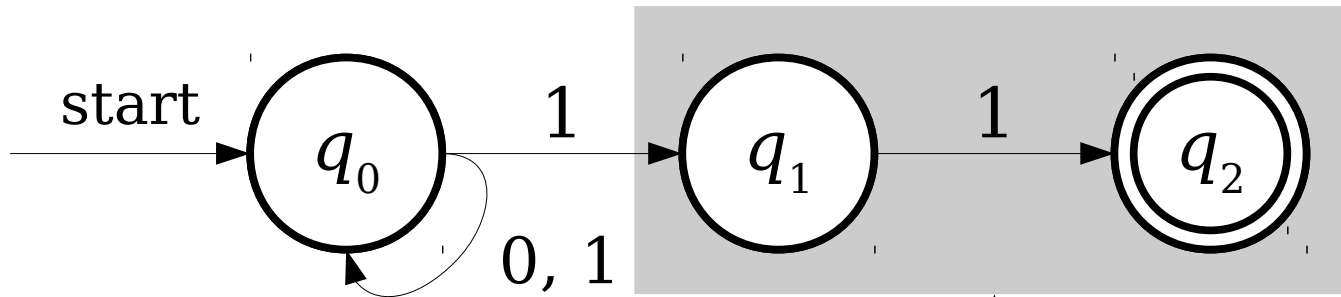

If a NFA needs to make a transition when no transition exists, the automaton **dies** and that particular path does not accept.

A More Complex NFA

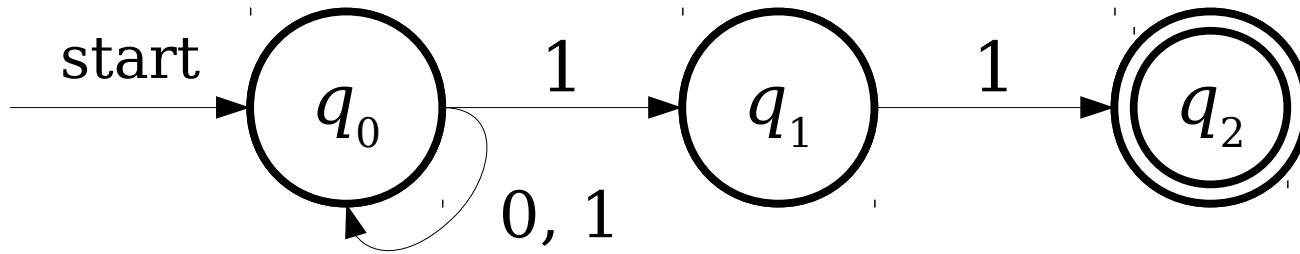

0 1 0 1 1

A More Complex NFA

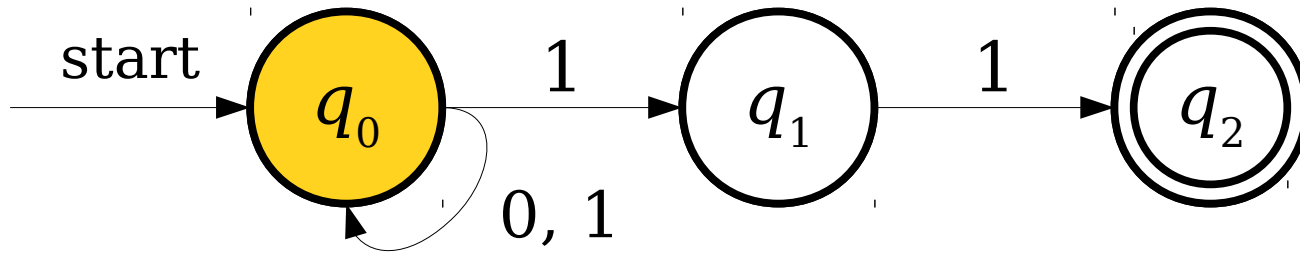

0 1 0 1 1

A More Complex NFA

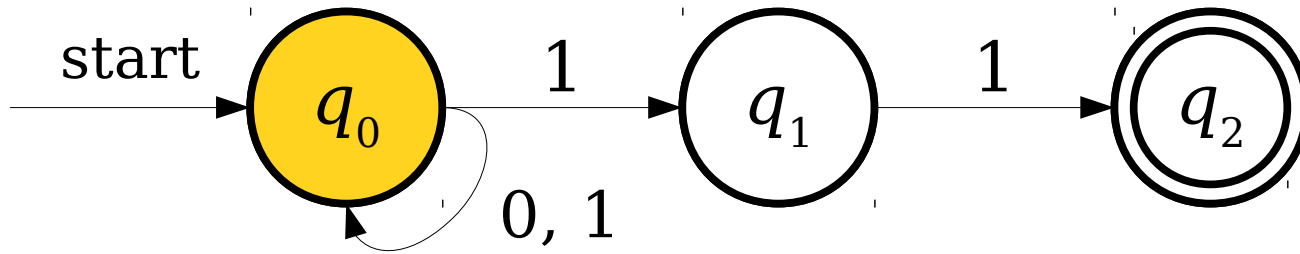

0 1 0 1 1

A green arrow points upwards to the first character '0' of the string '0 1 0 1 1'.

A More Complex NFA

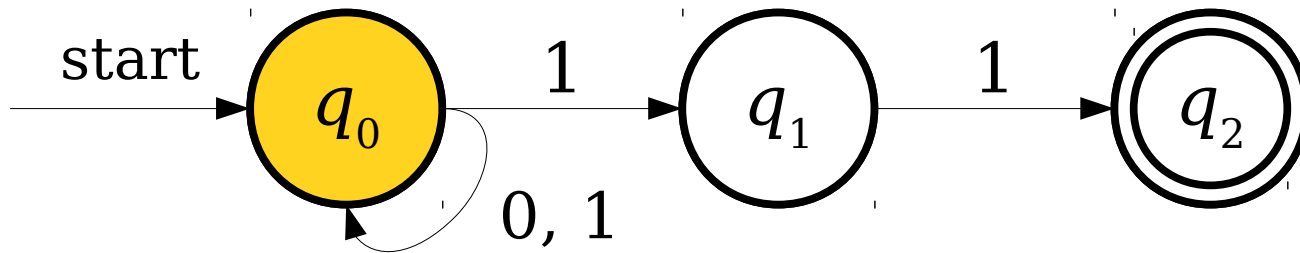

0 1 0 1 1

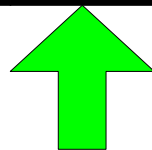

A More Complex NFA

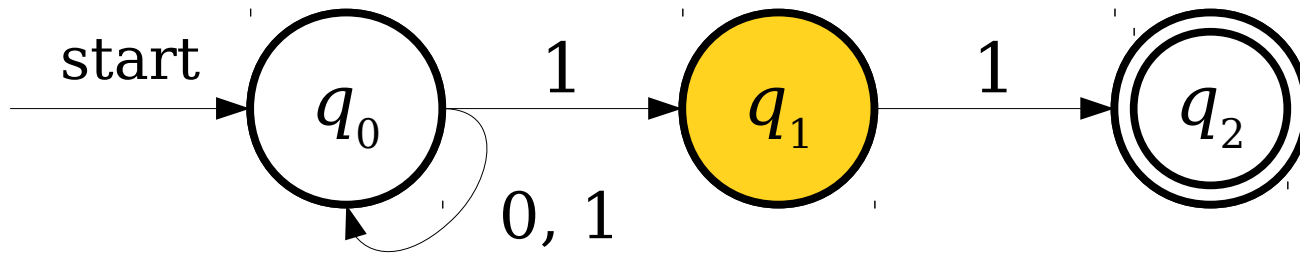

0 1 0 1 1

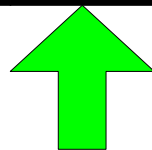

A More Complex NFA

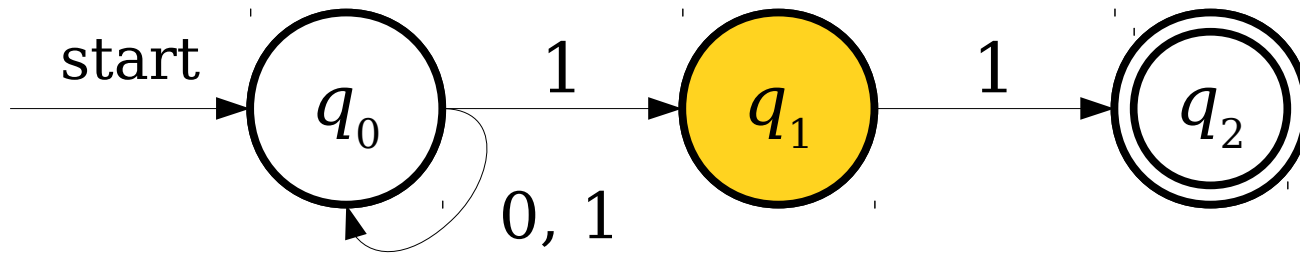

0 1 0 1 1

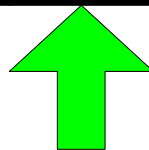

A More Complex NFA

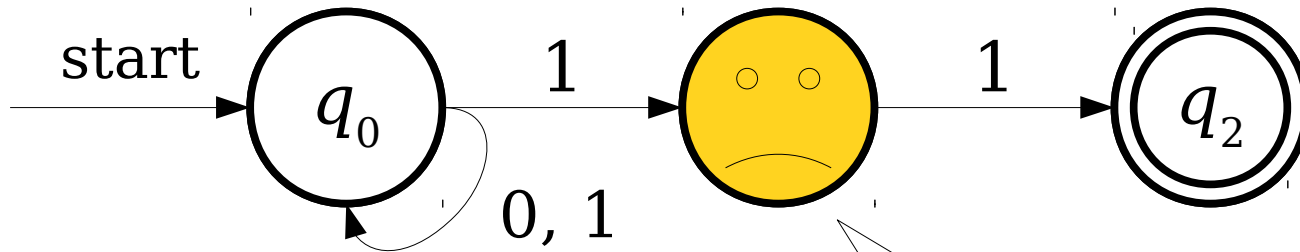

Oh no! There's no transition defined!

0 1 0 1 1

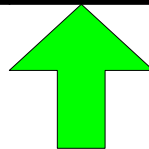

A More Complex NFA

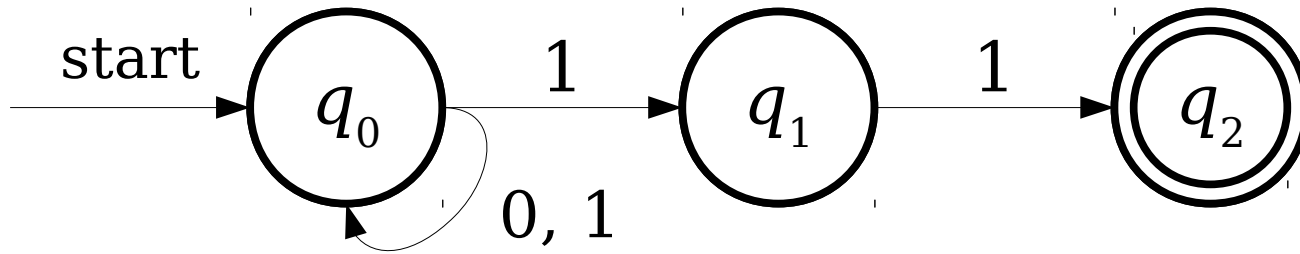

0 1 0 1 1

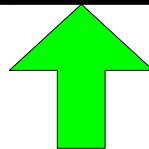

A More Complex NFA

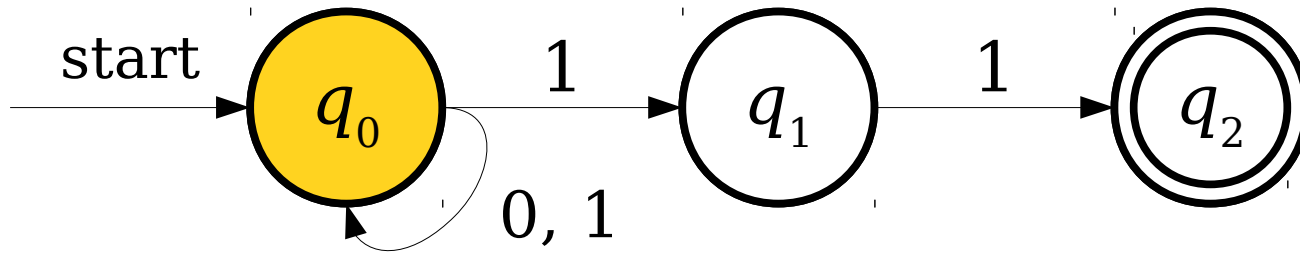

0 1 0 1 1

A green arrow points to the first character '0' of the string.

A More Complex NFA

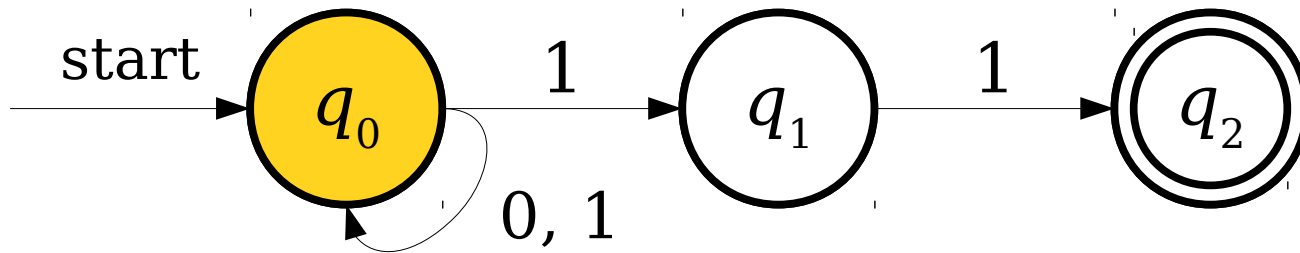

0 1 0 1 1

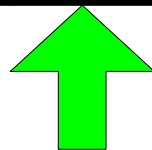

A More Complex NFA

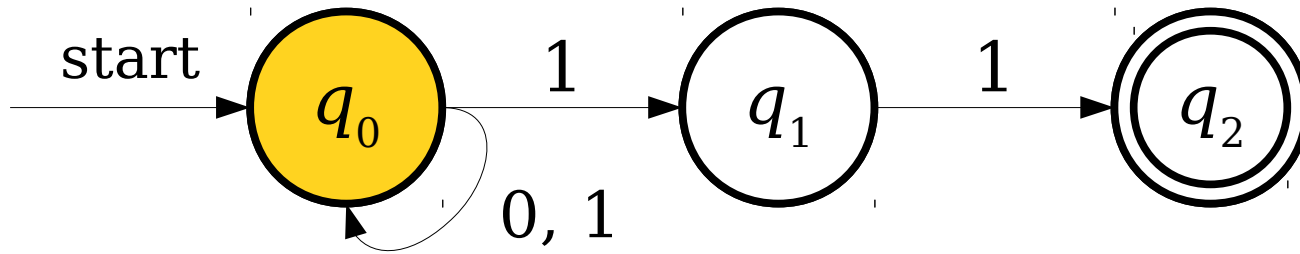

0 1 0 1 1

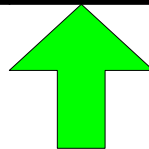

A More Complex NFA

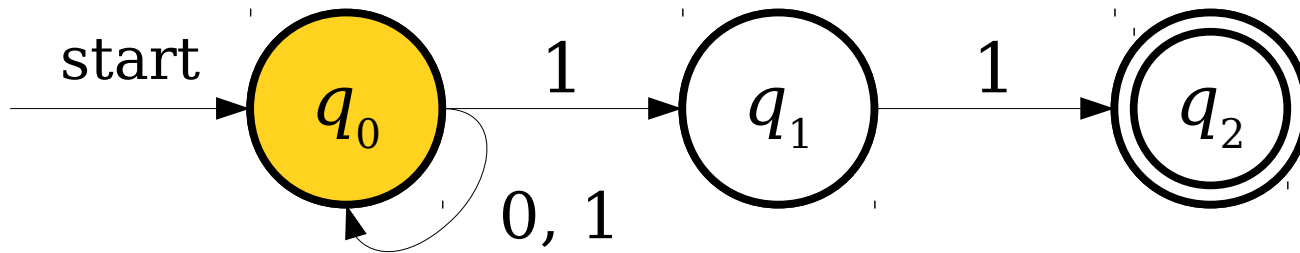

0 1 0 1 1



A More Complex NFA

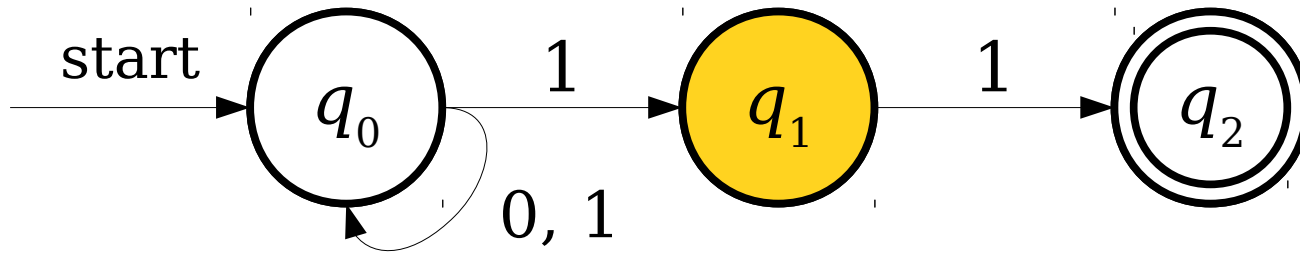

0 1 0 1 1



A More Complex NFA

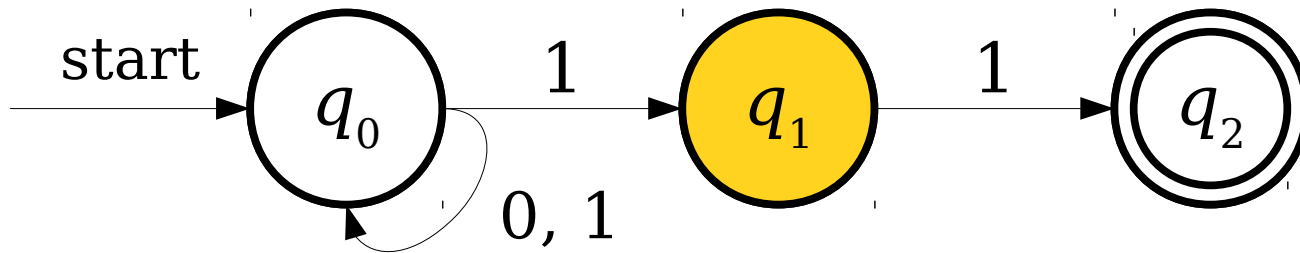

0 1 0 1 1

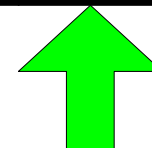

A More Complex NFA

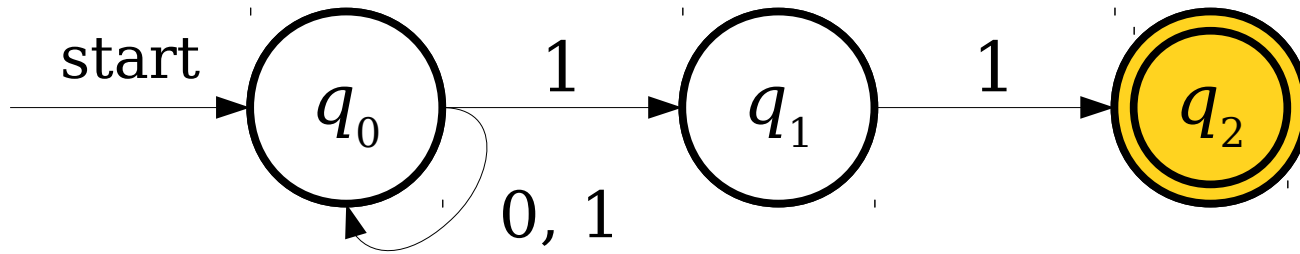

0 1 0 1 1

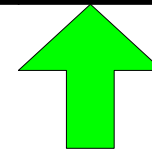

A More Complex NFA

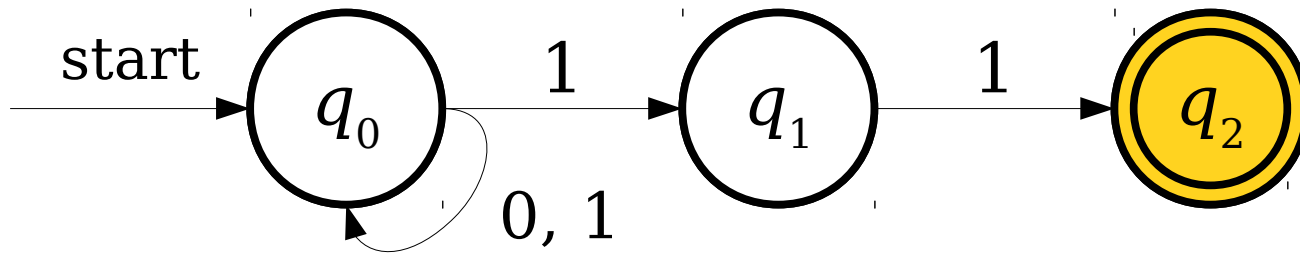

0 1 0 1 1

A More Complex NFA

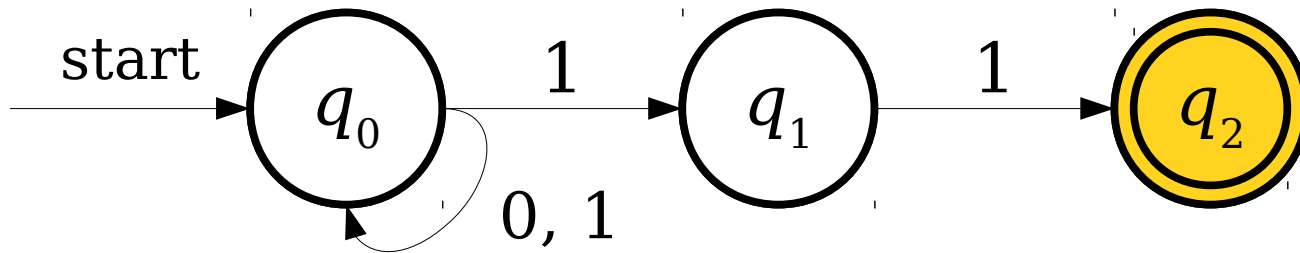

0 1 0 1 1

A More Complex NFA

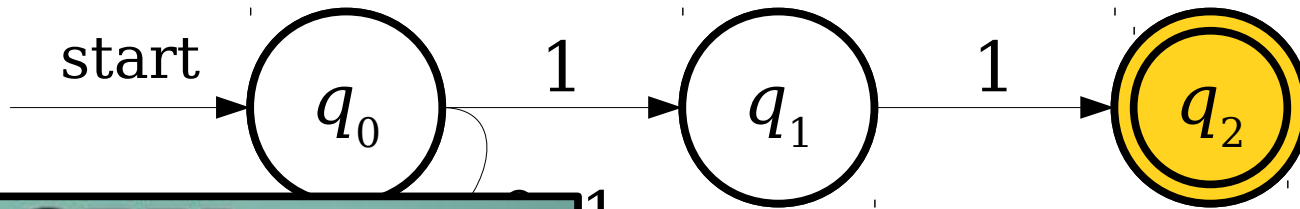

0 1 1

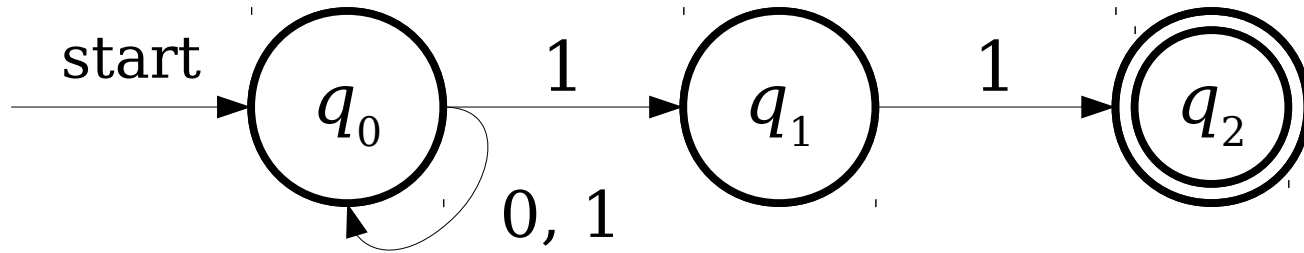

As with DFAs, the language of an NFA N is the set of strings that N accepts:

$$\mathcal{L}(N) = \{ w \in \Sigma^* \mid N \text{ accepts } w \}.$$

What is the language of the NFA shown above?

- A. { **01011** }
- B. { $w \in \{0, 1\}^* \mid w$ contains at least two **1s** }
- C. { $w \in \{0, 1\}^* \mid w$ ends with **1** }
- D. { $w \in \{0, 1\}^* \mid w$ ends with **11** }
- E. { $w \in \{0, 1\}^* \mid w$ ends with **111** }
- F. **None** of these, or **two or more** of these.

Answer at [PollEv.com/cs103](https://www.poll-ev.com/cs103) or
text **CS103** to **22333** once to join, then **A**, ..., or **F**.

NFA Acceptance

- An NFA N accepts a string w if there is some series of choices that lead to an accepting state.
- Consequently, an NFA N rejects a string w if *no possible* series of choices lead it into an accepting state.
- It's easier to show that an NFA does accept something than to show that it doesn't.

ϵ -Transitions

- NFAs have a special type of transition called the **ϵ -transition**.
- An NFA may follow any number of ϵ -transitions at any time without consuming any input.

ϵ -Transitions

- NFAs have a special type of transition called the **ϵ -transition**.
- An NFA may follow any number of ϵ -transitions at any time without consuming any input.

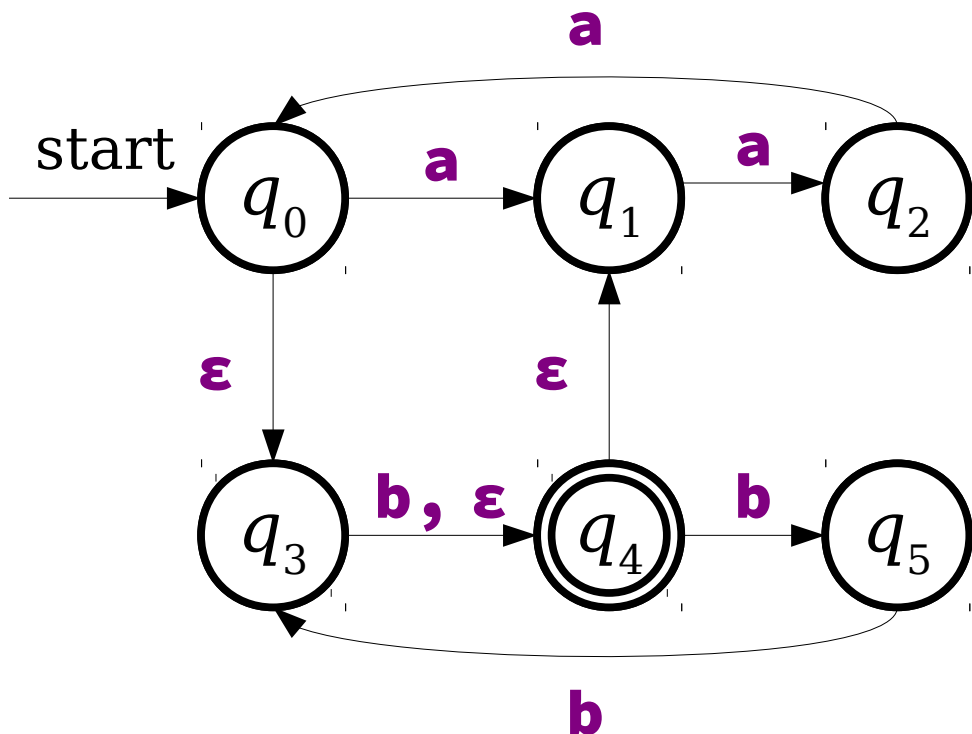

ϵ -Transitions

- NFAs have a special type of transition called the **ϵ -transition**.
- An NFA may follow any number of ϵ -transitions at any time without consuming any input.

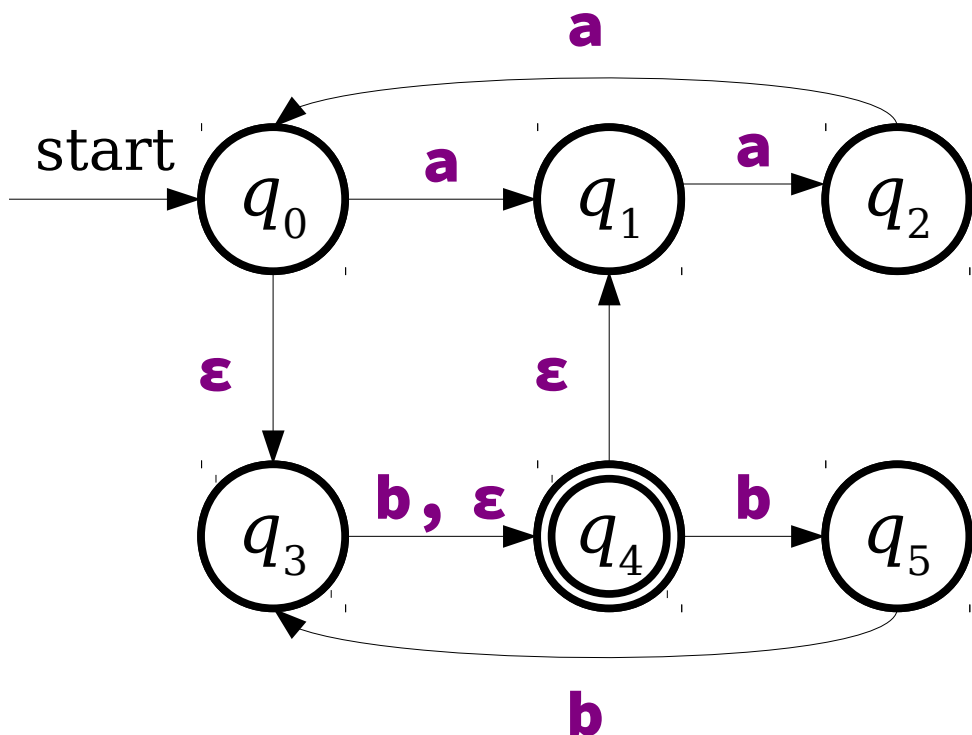

b a a b b

ϵ -Transitions

- NFAs have a special type of transition called the **ϵ -transition**.
- An NFA may follow any number of ϵ -transitions at any time without consuming any input.

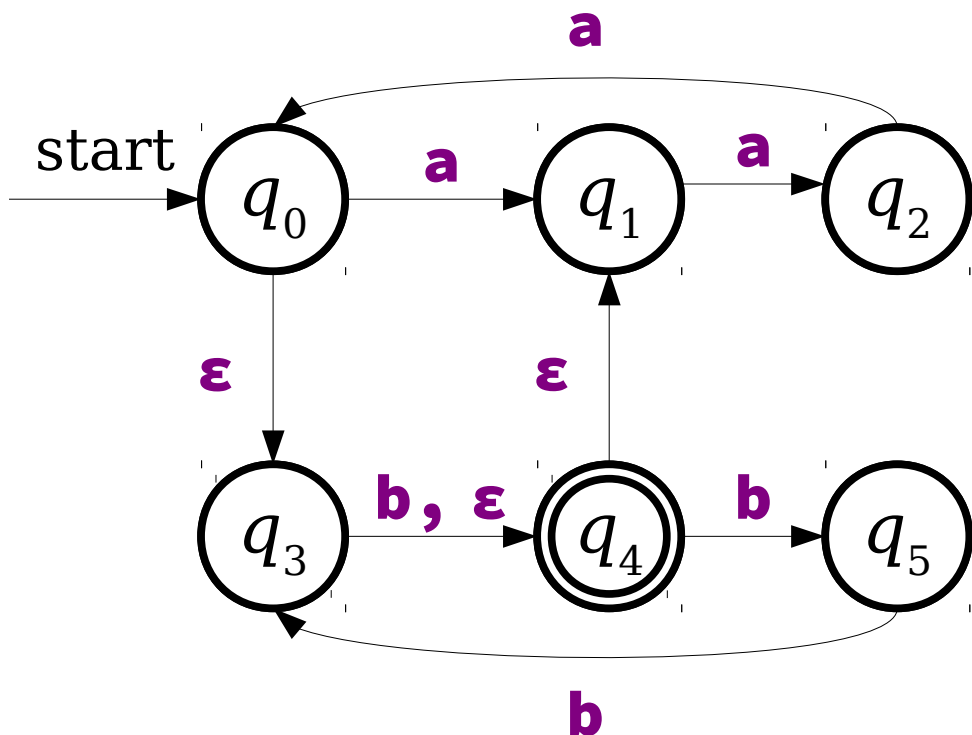

ϵ -Transitions

- NFAs have a special type of transition called the **ϵ -transition**.
- An NFA may follow any number of ϵ -transitions at any time without consuming any input.

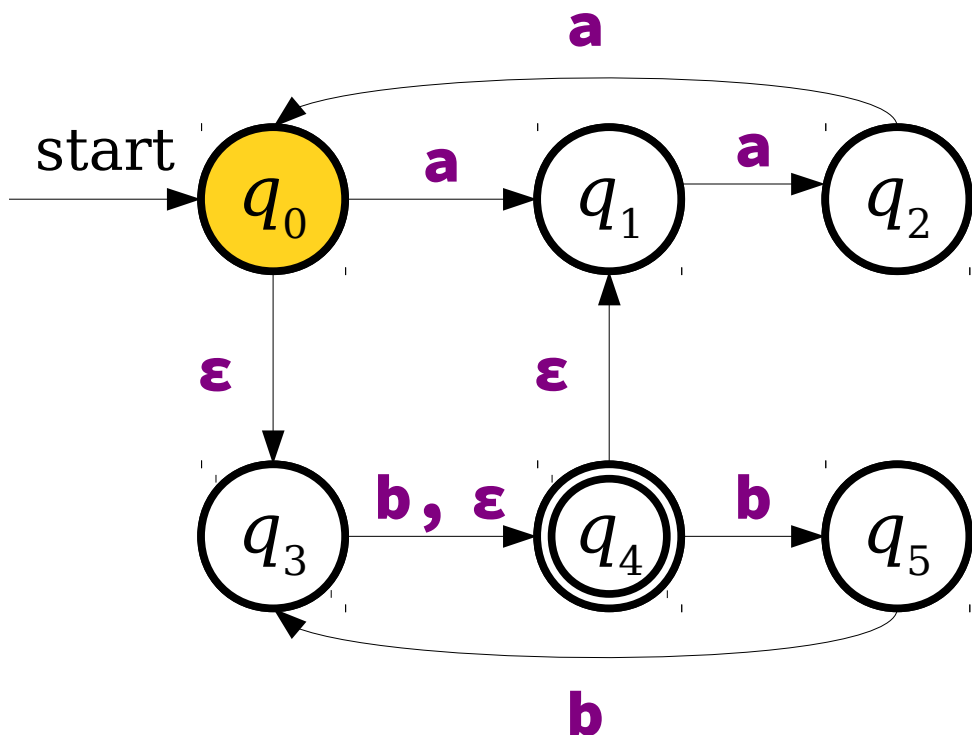

ϵ -Transitions

- NFAs have a special type of transition called the **ϵ -transition**.
- An NFA may follow any number of ϵ -transitions at any time without consuming any input.

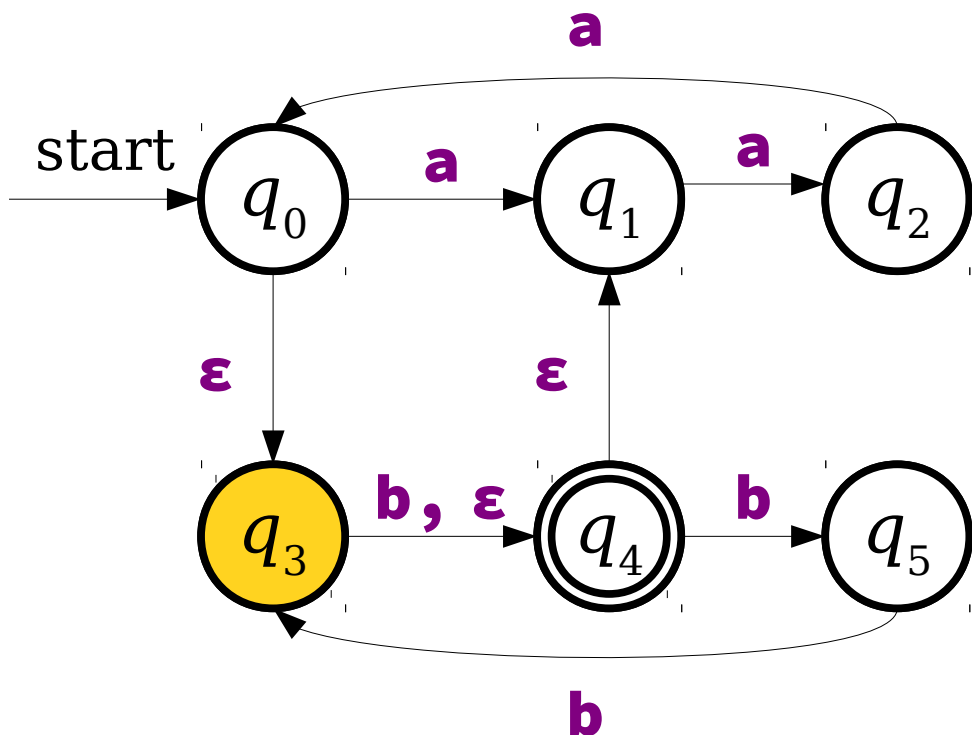

ϵ -Transitions

- NFAs have a special type of transition called the **ϵ -transition**.
- An NFA may follow any number of ϵ -transitions at any time without consuming any input.

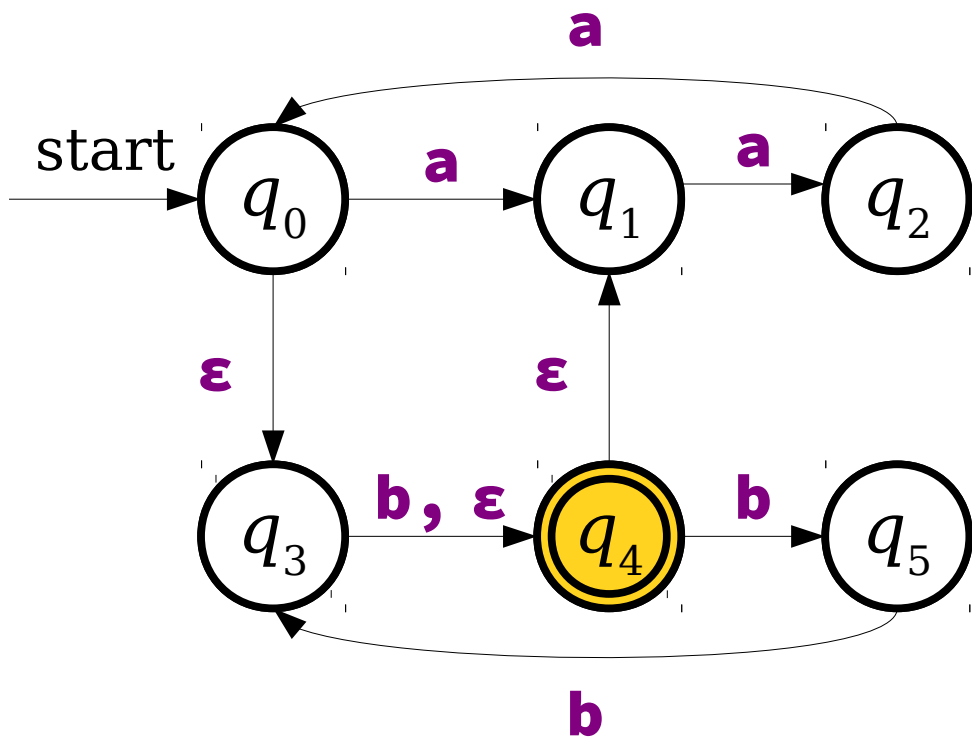

ϵ -Transitions

- NFAs have a special type of transition called the **ϵ -transition**.
- An NFA may follow any number of ϵ -transitions at any time without consuming any input.

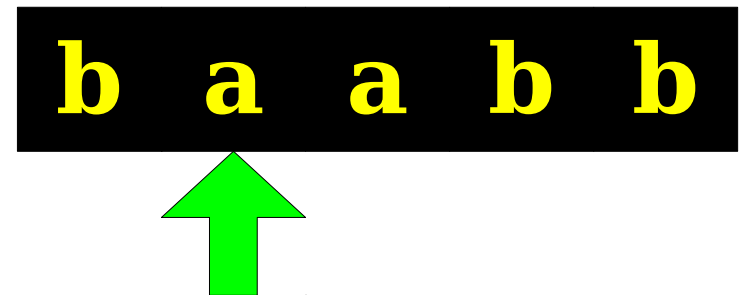
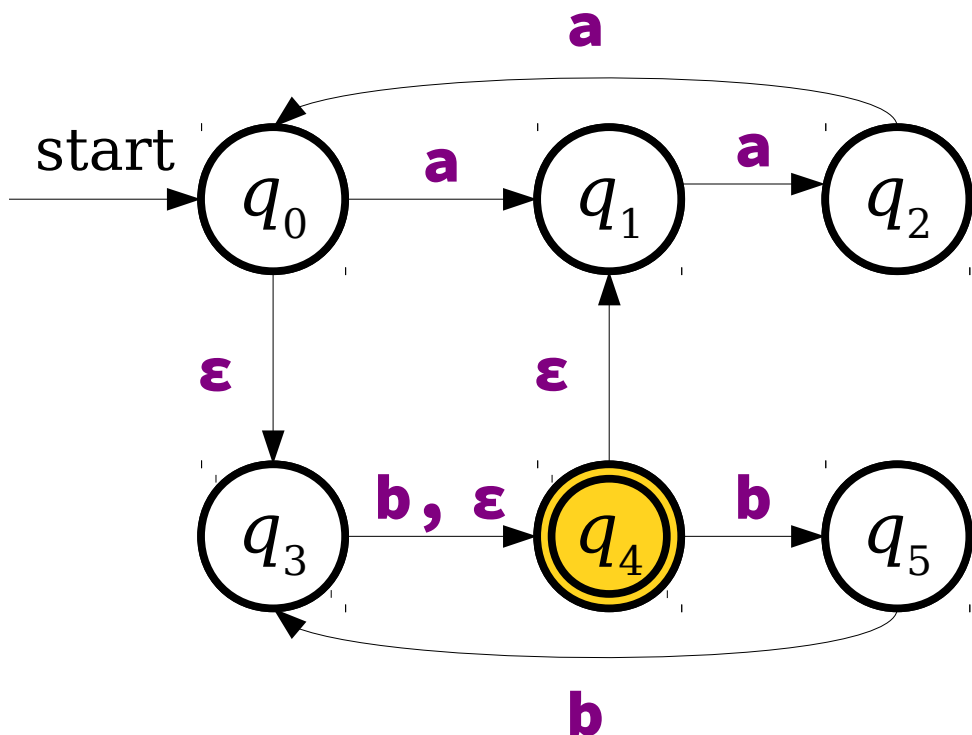

ϵ -Transitions

- NFAs have a special type of transition called the **ϵ -transition**.
- An NFA may follow any number of ϵ -transitions at any time without consuming any input.

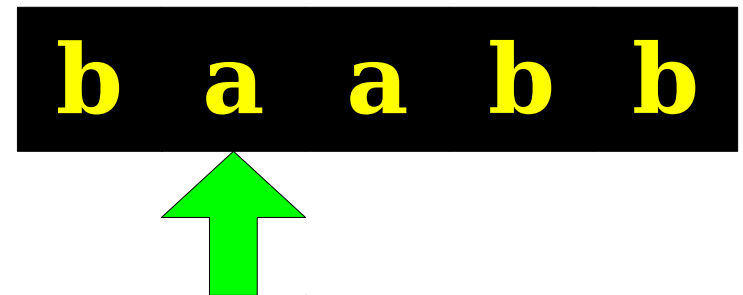
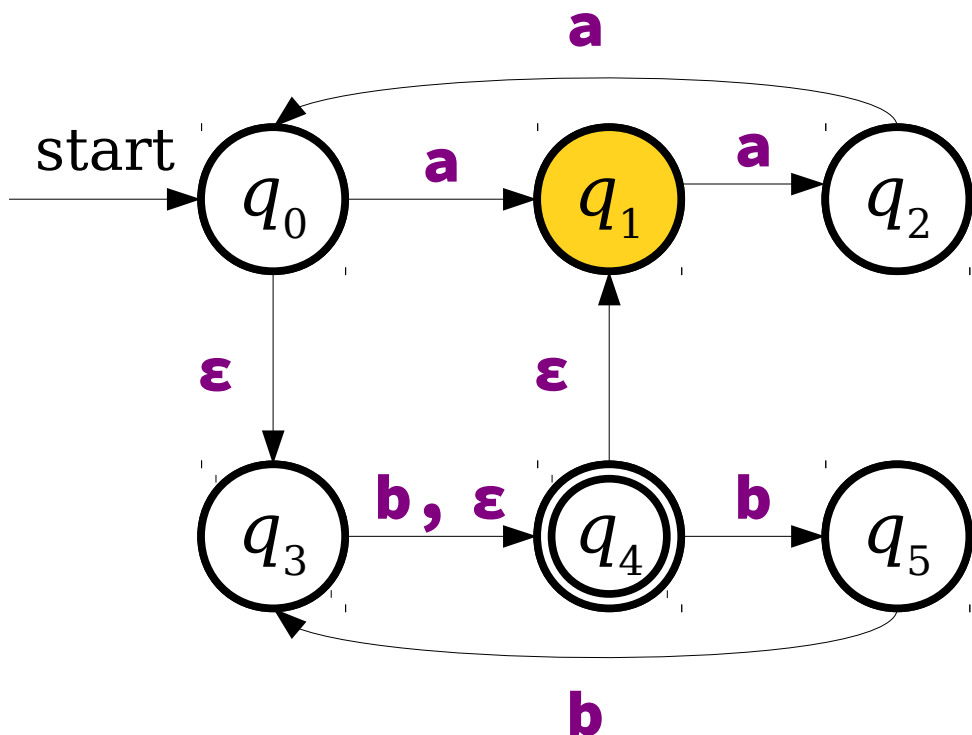

ϵ -Transitions

- NFAs have a special type of transition called the **ϵ -transition**.
- An NFA may follow any number of ϵ -transitions at any time without consuming any input.

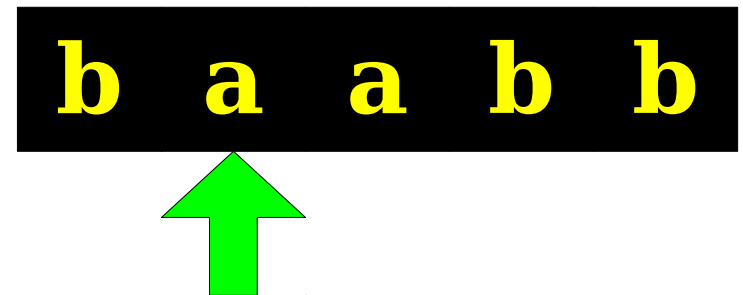
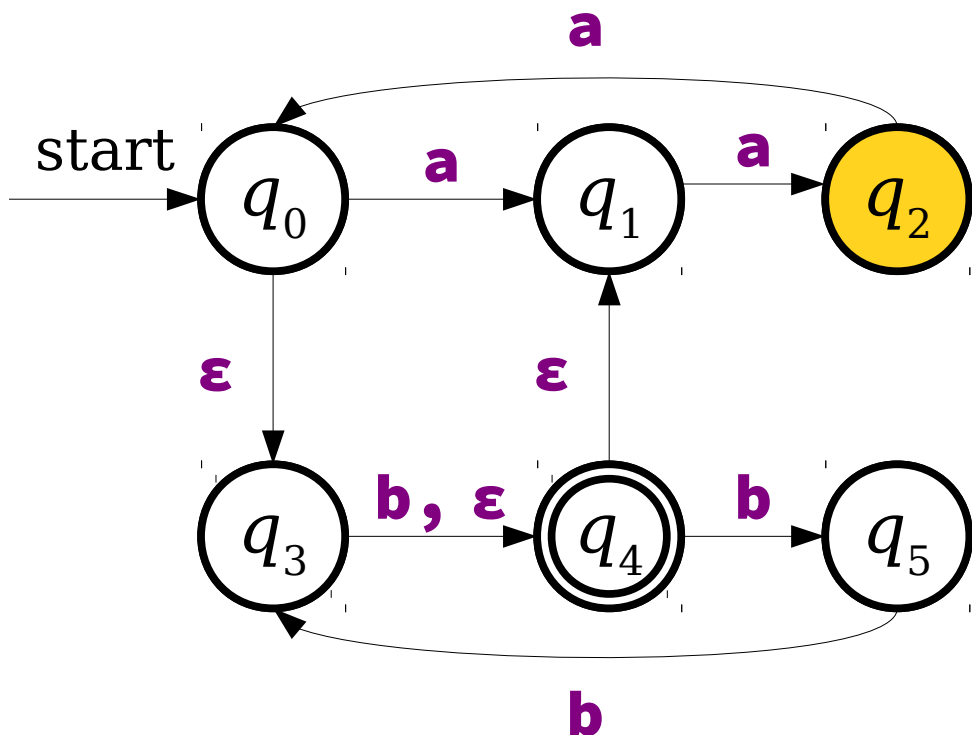

ϵ -Transitions

- NFAs have a special type of transition called the **ϵ -transition**.
- An NFA may follow any number of ϵ -transitions at any time without consuming any input.

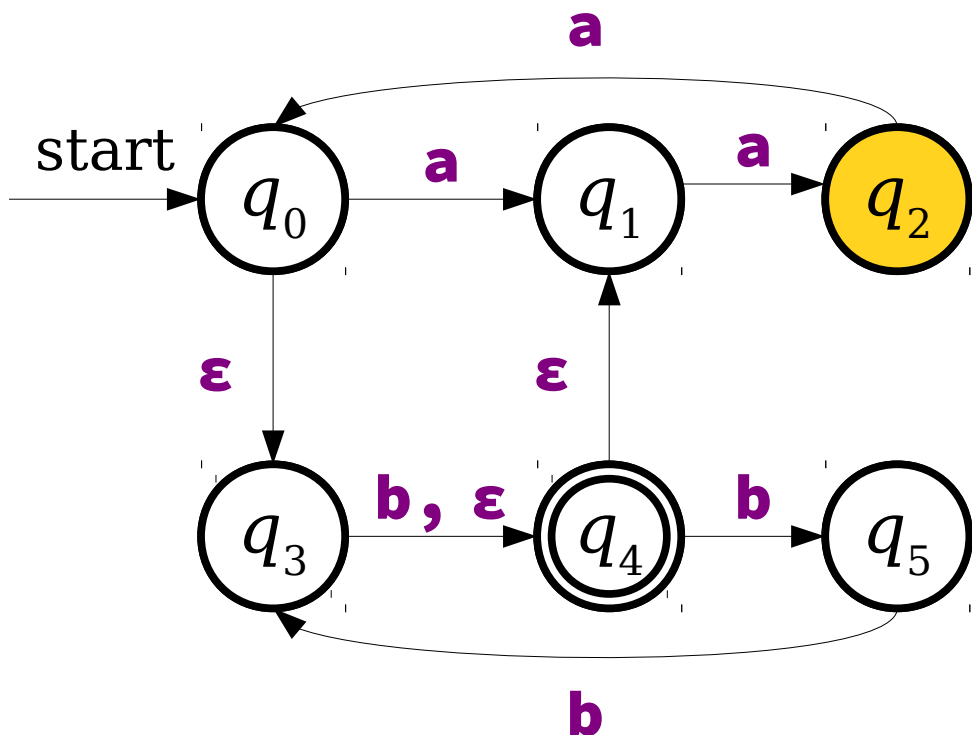

b a a b b

ϵ -Transitions

- NFAs have a special type of transition called the **ϵ -transition**.
- An NFA may follow any number of ϵ -transitions at any time without consuming any input.

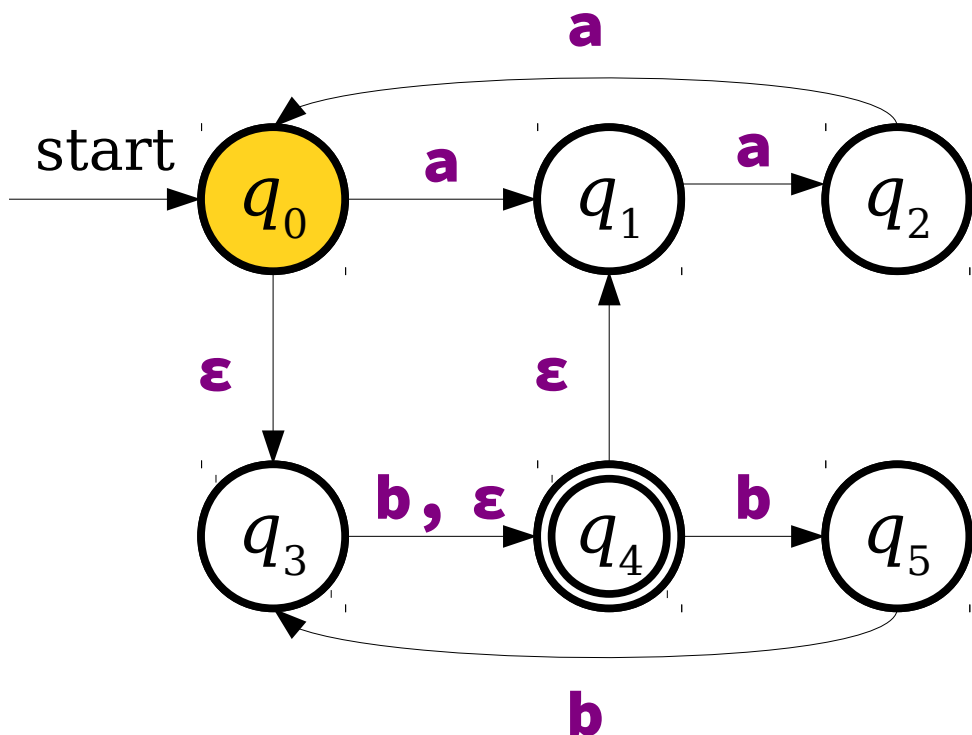

b a a b b

ϵ -Transitions

- NFAs have a special type of transition called the **ϵ -transition**.
- An NFA may follow any number of ϵ -transitions at any time without consuming any input.

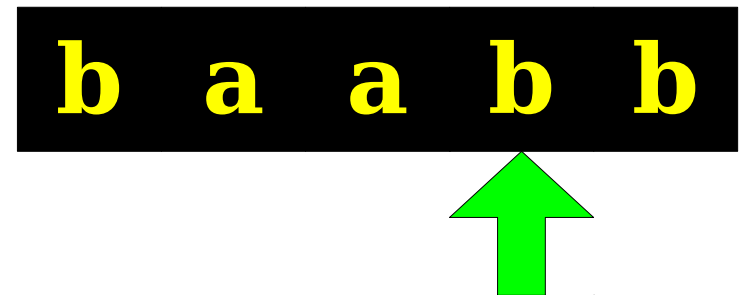
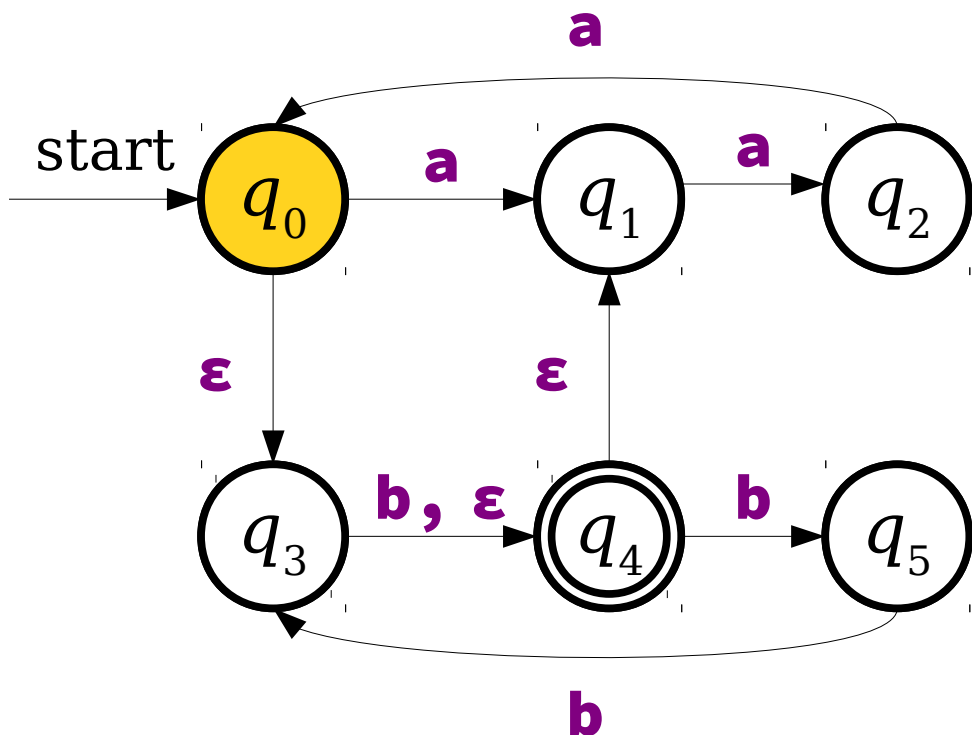

ϵ -Transitions

- NFAs have a special type of transition called the **ϵ -transition**.
- An NFA may follow any number of ϵ -transitions at any time without consuming any input.

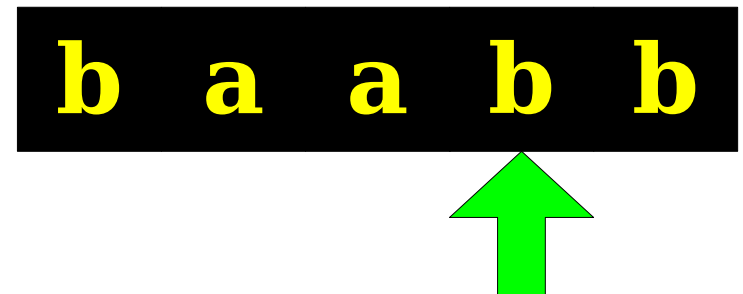
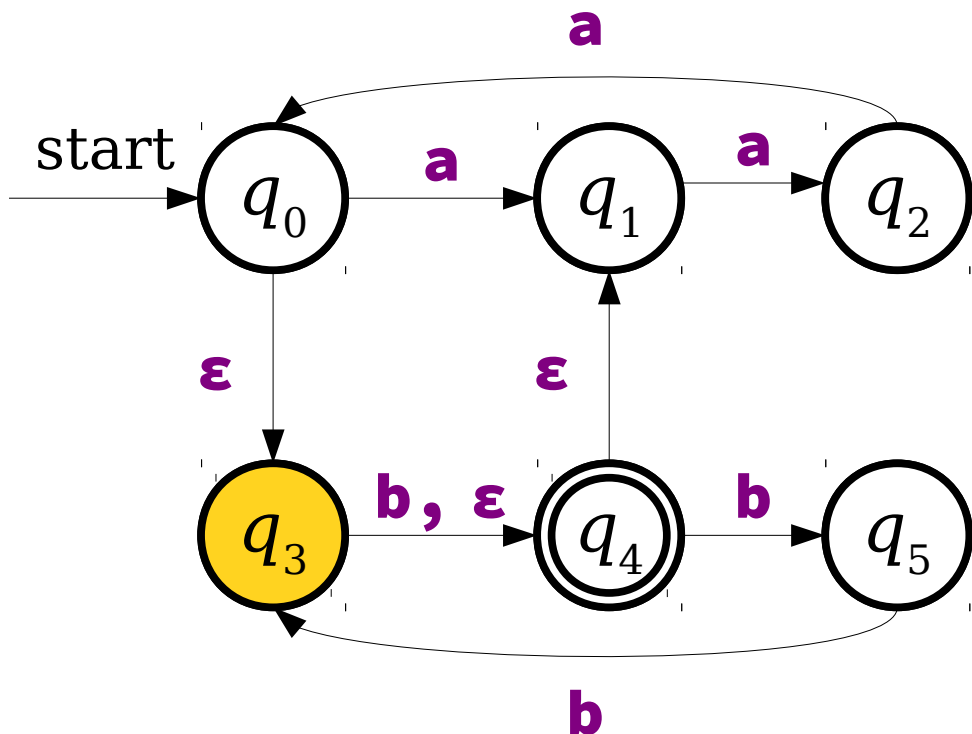

ϵ -Transitions

- NFAs have a special type of transition called the **ϵ -transition**.
- An NFA may follow any number of ϵ -transitions at any time without consuming any input.

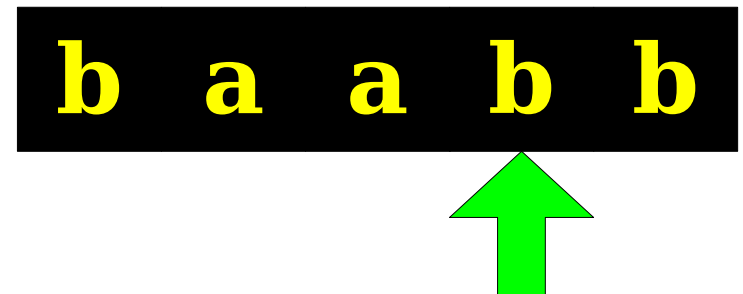
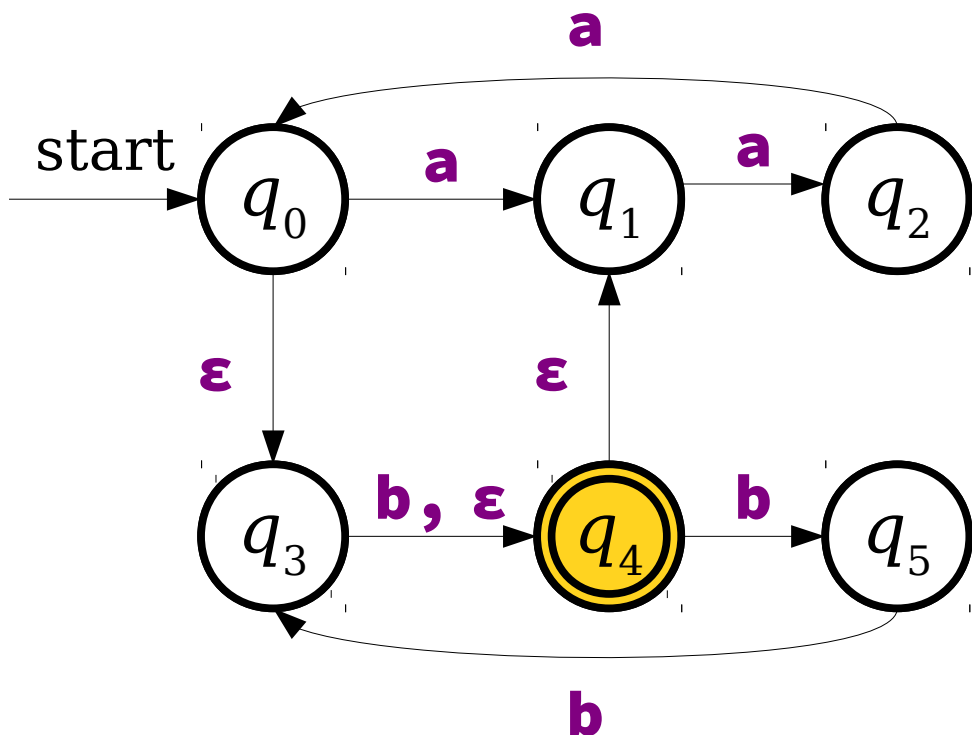

ϵ -Transitions

- NFAs have a special type of transition called the **ϵ -transition**.
- An NFA may follow any number of ϵ -transitions at any time without consuming any input.

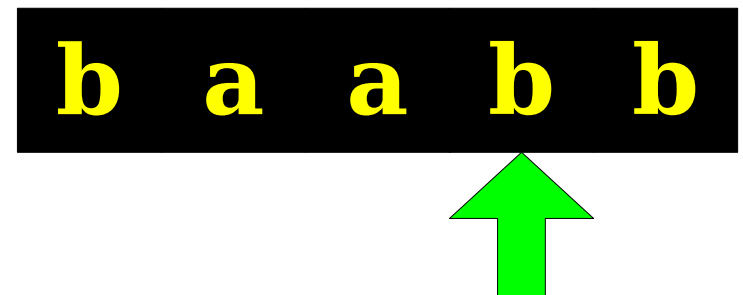
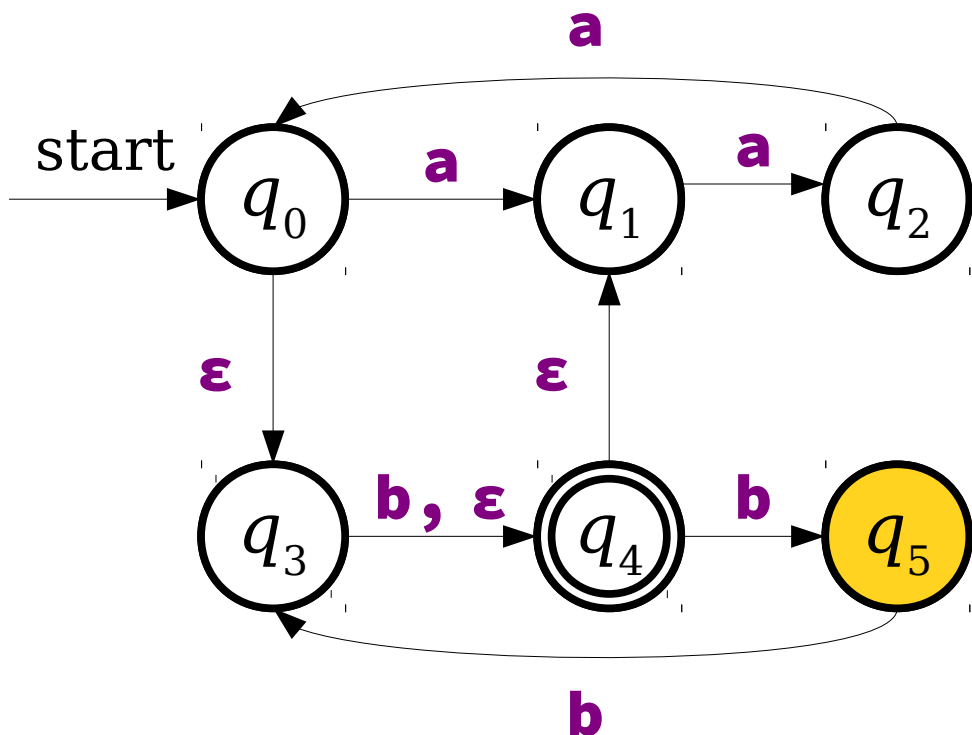

ϵ -Transitions

- NFAs have a special type of transition called the **ϵ -transition**.
- An NFA may follow any number of ϵ -transitions at any time without consuming any input.

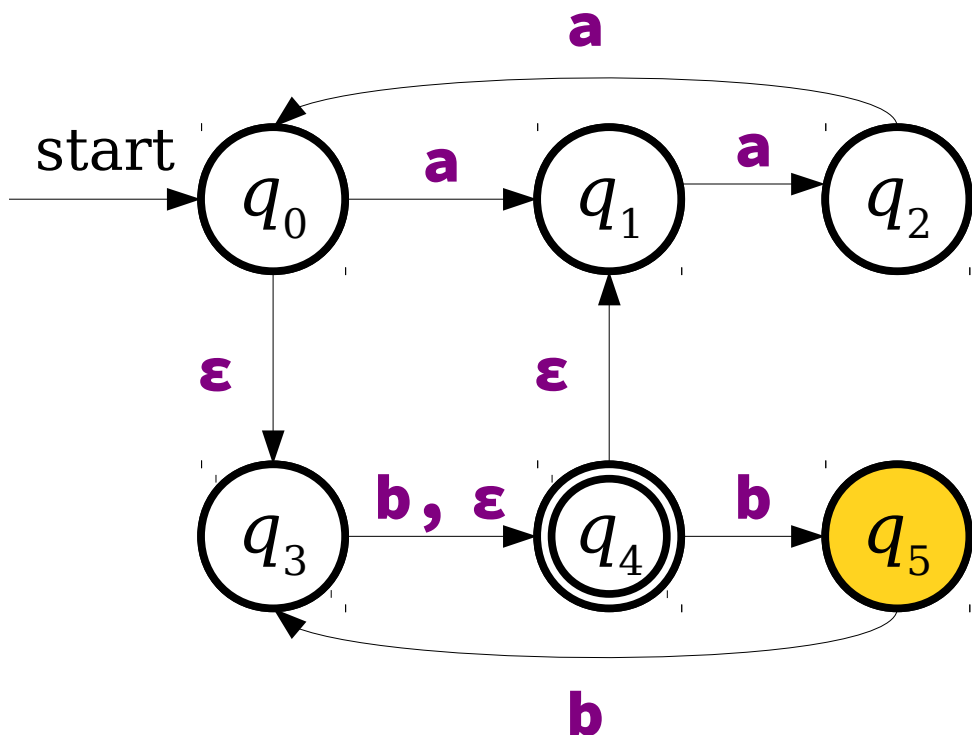

b a a b b

A green arrow points to the final 'b' in the string "b a a b b".

ϵ -Transitions

- NFAs have a special type of transition called the **ϵ -transition**.
- An NFA may follow any number of ϵ -transitions at any time without consuming any input.

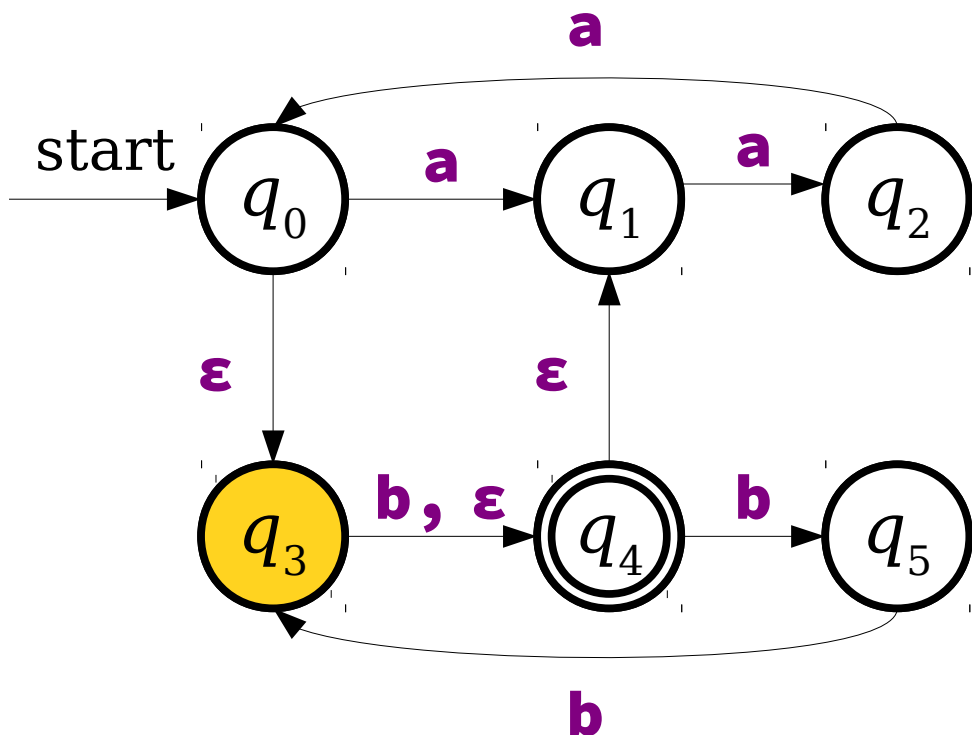

b a a b b

A green arrow points to the final 'b' in the string "b a a b b".

ϵ -Transitions

- NFAs have a special type of transition called the **ϵ -transition**.
- An NFA may follow any number of ϵ -transitions at any time without consuming any input.

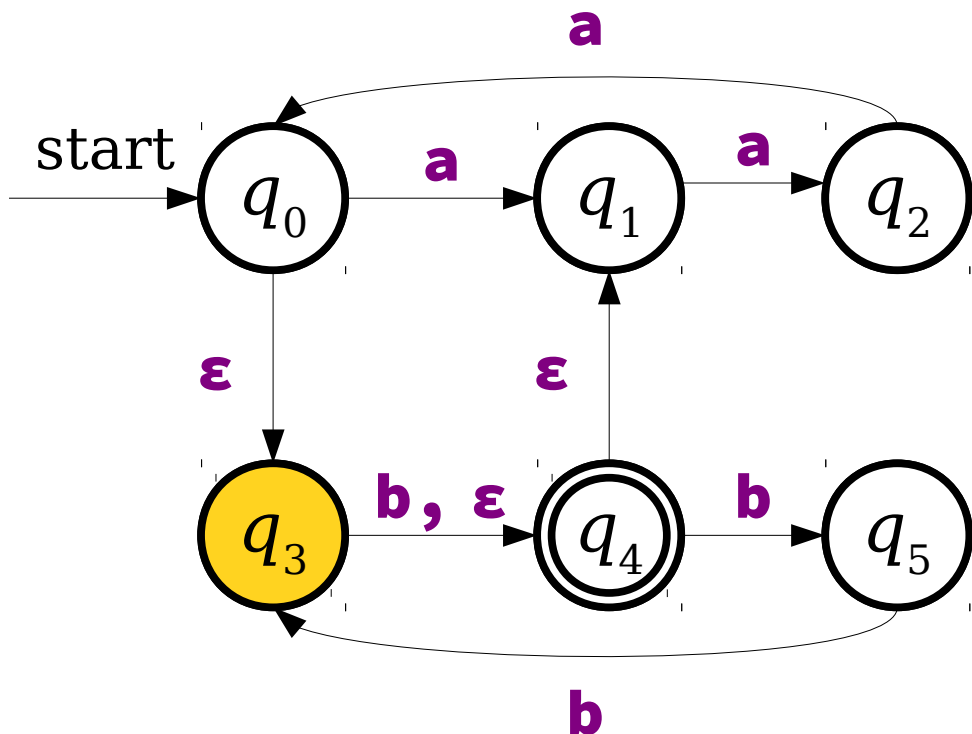

b a a b b

ϵ -Transitions

- NFAs have a special type of transition called the **ϵ -transition**.
- An NFA may follow any number of ϵ -transitions at any time without consuming any input.

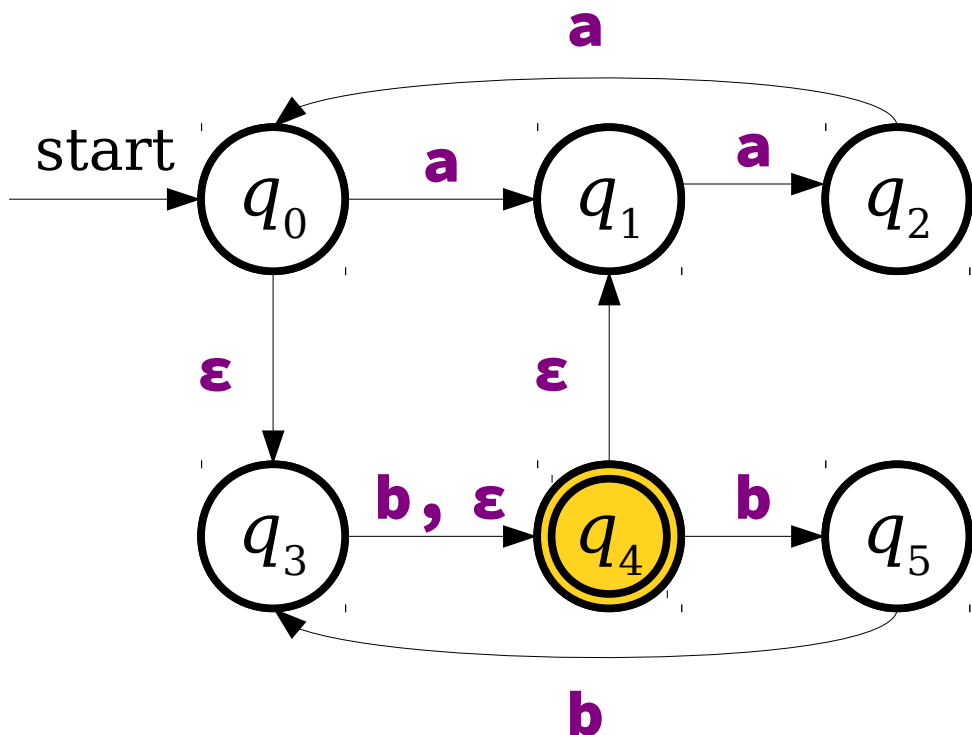

b a a b b

ϵ -Transitions

- NFAs have a special type of transition called the **ϵ -transition**.
- An NFA *may* follow any number of ϵ -transitions at any time without consuming any input.
- NFAs are not *required* to follow ϵ -transitions every time one is available. It's simply another option at the machine's disposal (stay or move).

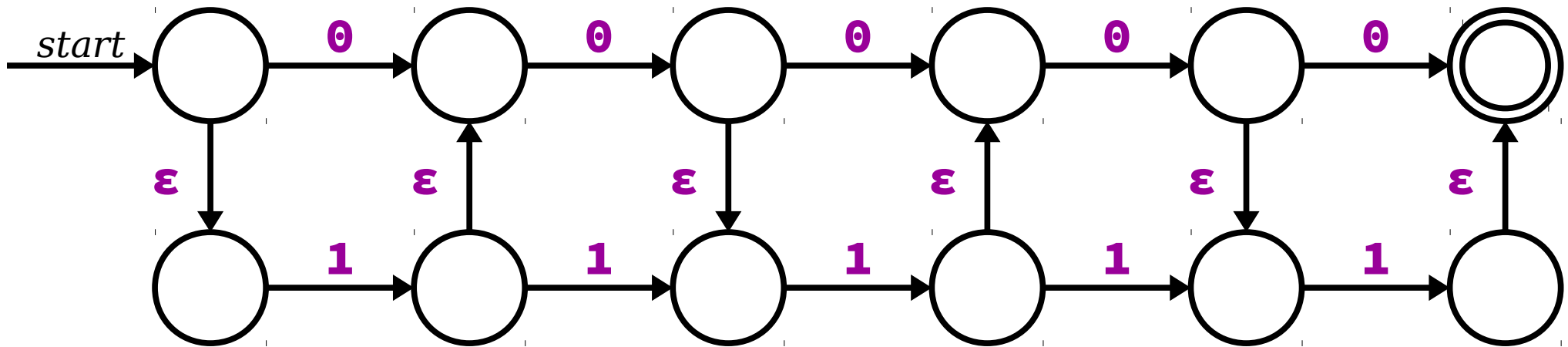

Suppose we run the above NFA on the string **10110**. How many of the following statements are true?

- There is at least one computation that finishes in an accepting state.
- There is at least one computation that finishes in a rejecting state.
- There is at least one computation that dies.
- This NFA accepts **10110**.
- This NFA rejects **10110**.

Answer at [PollEv.com/cs103](https://www.pollevo.com/cs103) or
text **CS103** to **22333** once to join, then a **number**.